

TECHNICAL MANUAL

OPERATOR'S, UNIT, DIRECT SUPPORT AND GENERAL SUPPORT MAINTENANCE MANUAL

FOR PORTABLE SHOWER MODULE MODEL SHOWER-1 (4510-01-163-6775)

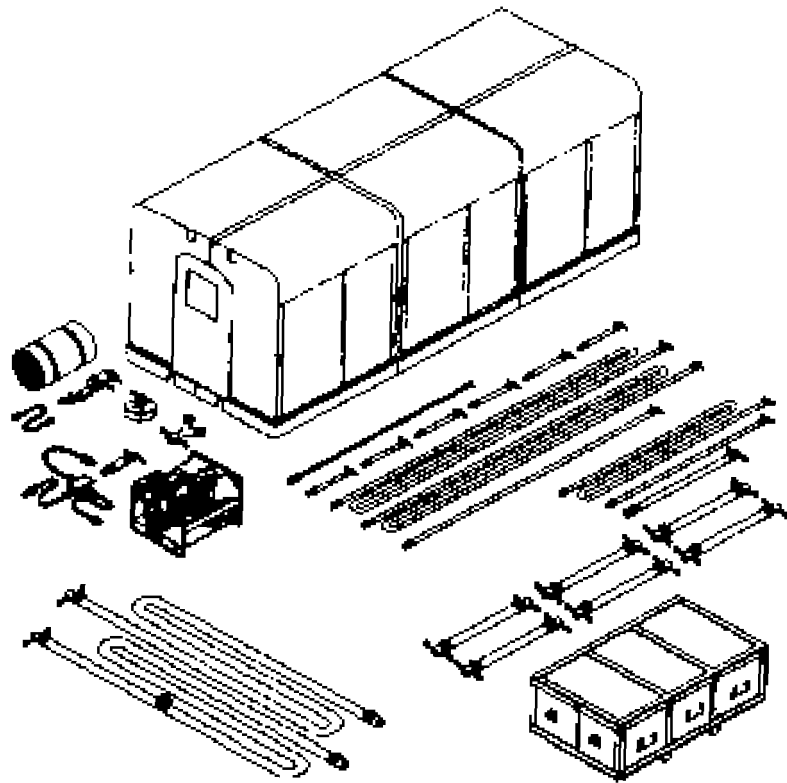

DISTRIBUTION STATEMENT A: Approved for public release; distribution is unlimited.

**HEADQUARTERS, DEPARTMENT OF THE ARMY
30 AUGUST 2000**

THIS PAGE INTENTIONALLY LEFT BLANK

WARNING

HIGH PRESSURE

Do not open hose couplings when the water system is under pressure. Hose end can whip causing injury to personnel and equipment damage.

HEAVEY EQUIPMENT

Lifting or moving heavy equipment incorrectly can cause serious injury. Do not try to lift or move more than 50 pounds by yourself. Get an assistant. Bend legs while lifting. Don't support heavy weight with your back.

HIGH VOLTAGE

Voltage used in the pump assembly and power cables can kill. Be sure power has been disconnected form any component being serviced.

SLIPPERY SURFACE

Shower stall surfaces are very slippery when wet. Use extreme caution to avoid injury due to loss of footing.

FIRST AID

For first aid procedure, refer to FM 21-11.

THIS PAGE INTENTIONALLY LEFT BLANK

TECHNICAL MANUAL
NO. 10-4510-207-14

HEADQUARTERS
DEPARTMENT OF THE ARMY
WASHINGTON, D.C., 30 August 2000

**OPERATOR’S, UNIT, DIRECT SUPPORT
AND GENERAL SUPPORT MAINTENANCE MANUAL
FOR
PORTABLE SHOWER MODULE, MODEL SHOWER-1 (4510-01-163-6774)**

REPORTING ERRORS AND RECOMMENDING IMPROVEMENTS

You can help improve this manual. If you find any mistakes, or if you know of a way to improve these procedures, please let us know. Mail your letter or DA Form 2028 (Recommended Changes to Publications and Blank Forms), or DA Form 2028-2 located in the back of this manual, directly to: Commander, U.S. Army Soldier and Biological Chemical Command, ATTN: AMSSB-RIM-E(N), Kansas Street, Natick, MA 01760-5052. You may also submit your recommended changes by E-mail directly to <amssb-rim-e@natick.army.mil>. A reply will be furnished directly to you

TABLE OF CONTENTS

	Page
CHAPTER 1 INTRODUCTION.....	1-1
Section I Equipment Description and Data.....	1-2
Section II Principles of Operation	1-6
CHAPTER 2 OPERATING INSTRUCTIONS	2-1
Section I Description and Use of Operator’s Control and indications.....	2-1
Section II Operator Preventive Maintenance Checks and Services.....	2-3
Section III Operations Under Usual Conditions.....	2-7
Section IV Operations Under Unusual Conditions	2-15
CHAPTER 3 OPERATOR MAINTENANCE INSTRUCTIONS.....	3-1
Section I Lubrication Instructions	3-1
Section II Operator Troubleshooting Procedures	3-1
Section III Operator Maintenance Procedures	3-4
CHAPTER 4 UNIT MAINTENANCE INSTRUCTIONS.....	4-1
Section I Repair Parts, Tools, Test, Measurement, Diagnostic Equipment (TMDA) and Support Equipment.....	4-1
Section II Unit Preventive Maintenance Checks and Services (PMCS)	4-2
Section III Unit Troubleshooting Procedures.....	4-6
Section IV Unit Maintenance Procedures	4-7
Section V Preparation for Storage or Shipment.....	4-43
CHAPTER 5 DIRECT SUPPPORT MAINTENANCE INSTRUCTIONS.....	5-1

CHAPTER 6	GENERAL SUPPORT MAINTENANCE INSTRUCTIONS	6-1
APPENDIX A	REFERENCE	A-1
APPENDIX B	MAINTENANCE ALLOCAITON CHART	B-1
Section I	Introduction.....	B-1
Section II	Maintenance Allocation Chart for Portable Shower Module	B-3
Section III	Tools and Test Equipment for Portable Shower Module.....	B-5
Section IV	Remarks for Portable Shower Module.....	B-5
APPENDIX C	COMPONENTS OF END ITEM (COEI) AND BASIC ISSUE ITEMS LIST (BII).....	C-1
Section I	Introduction.....	C-1
Section II	Components of End Item.....	C-2
Section III	Basic Issue Items list.....	C-4
APPENDIX D	ADDITIONAL AUTHORIZATION LIST (AAL)	D-1
APPENDIX E	EXPENDABLE AND DURABLE ITEMS LIST	E-1
Section I	Introduction.....	E-1
Section II	Expendable and Durable Items List	E-1
APPENDIX F	ILLUSTRATED LIST OF MANUFACTURED ITEMS.....	F-2
Section I	Introduction.....	F-2
Section II	Manufactured Items Illustrations	F-3
APPENDIX G	MANDANTORY REPLACEMENT PARTS.....	G-1
ALPHABETICAL INDEX		Index-1

LIST OF ILLUSTRATIONS

Figure	Title	Page
1-1	Portable Shower Module	1-0
1-2	Major Components.....	1-3
1-3	Identification Plate	1-4
2-1	Operating Controls and Indicators	2-2
2-2	Operator's PMCS Routing Diagram	2-4
2-3	Component Placement.....	2-9
2-4	Shower Facility Assembly	2-11
2-5	Hose Connections.....	2-13
3-1	Y-Fitting Coupler	3-4
3-2	Door Panel	3-5
3-3	Shower Cover.....	3-7
3-4	Floor Mat	3-8
3-5	Vertical Support.....	3-9
3-6	Floor Panel.....	3-10

4-1	Unit's PMCS Routing Diagram	4-3
4-2	Lubrication.....	4-5
4-3	Power Cable Assemblies	4-8
4-4	Portable Shower Base.....	4-10
4-5	Top Frame Assembly	4-13
4-6	Strainer Assembly	4-16
4-7	Spring Check Valve Assembly	4-18
4-8	Regulator Valve Assembly	4-20
4-9	Typical Shower Facility Interconnection Hose Assembly	4-22
4-10	Typical Shower Pump Cold Line Hose Assembly	4-24
4-11	Switch Box Assembly	4-26
4-12	Supply Pump Assembly	4-30
4-13	Regulator Assembly	4-33
4-14	Diaphragm (Drain) Pump Assembly.....	4-36
4-15	Diaphragm Tank & Fittings.....	4-39
4-16	Storage Container	4-42
4-17	Disconnect Hoses	4-44
4-18	Shower Facility Disassembly.....	4-46
5-1	Power Cable Assembly	5-2
5-2	Supply Pump Assembly	5-6
5-3	Diaphragm (Drain) Pump Assembly.....	5-9
5-4	Pump Assembly Frame.....	5-12
5-5	Storage Container	5-14
C-1	Components of End Item	C-2
C-2	Basic Issue Item.....	C-4
F-1	Electric Cable	F-3
F-2	Velcro Extrusion	F-3
F-3	Chain, Safety, Part Number 93107924/CHAIN	F-3
F-4	Hoses, Various.....	F-3
F-5	Electric Wire	F-3
F-6	Lumber	F-3
F-7	Plywood.....	F-3

LIST OF TABLES

Table	Title	Page
2-1	Operator Preventive Maintenance Checks and Services for SHOWER-1.....	2-5
2-2	Storage Container Contents.....	2-8
3-1	Operator Troubleshooting	3-1
4-1	Unit Preventive Maintenance Checks and Services for SHOWER-1.....	4-4
4-2	Unit Maintenance Troubleshooting	4-6
4-3	Storage Container Contents.....	4-47

HOW TO USE THIS MANUAL

Be sure to read all Warnings before using this manual

This manual contains instructions for operation and maintenance of the Portable Shower Module.

The front cover index of this manual list the area of the manual used most often and guides you to those sections. Follow the black mark on the cover index edge through the pages to the edge mark on the section you want. The subjects on the front cover index are also boxed in the table of content. A detailed alphabetical index is located at the back of the manual.

Chapter 1 - Introduces you to the equipment and gives you information such as weight and dimensions used and general theory of operation including principles of operation.

Chapter 2 - Provides the operator with information necessary to identify and service the equipment. Operating Instructions for usual and unusual conditions.

Chapter 3 - Provides operator lubrication tasks, and troubleshooting procedures for identifying common equipment malfunctions. Maintenance procedures for performing operator maintenance tasks.

Chapter 4 - Provides unit maintenance personnel with procedures for lubrication and service upon receipt of equipment and instructions for performing repairs on equipment as authorized by the maintenance allocation chart.

Chapter 5 - Provides direct support maintenance personnel with instructions for performing repairs on equipment as authorized by the maintenance allocation chart.

Chapter 6 - Provides general support maintenance personnel with instructions for performing repairs on equipment as authorized by the maintenance allocation chart.

Appendix A - Provides a list of frequently used forms and publications referenced of used in this manual.

Appendix B - The maintenance allocation chart identifies repairable components and the maintenance level authorized to perform the repairs.

Appendix C - List of components of end items and basic issue items to help you inventory the equipment.

Appendix D - Lists additional items that you are authorized for the support of the equipment.

Appendix E - List expendable and durable items needed to operate and maintain the equipment.

Appendix F - Provides you instruction for making items authorized to be manufactured or fabricated at unit, direct support and general support maintenance.

Appendix G - List all mandatory replacement part.

Alphabetical Index - Lists subject matter contained in manual in alphabetical order with the paragraph number.

THIS PAGE INTENTIONALLY LEFT BLANK

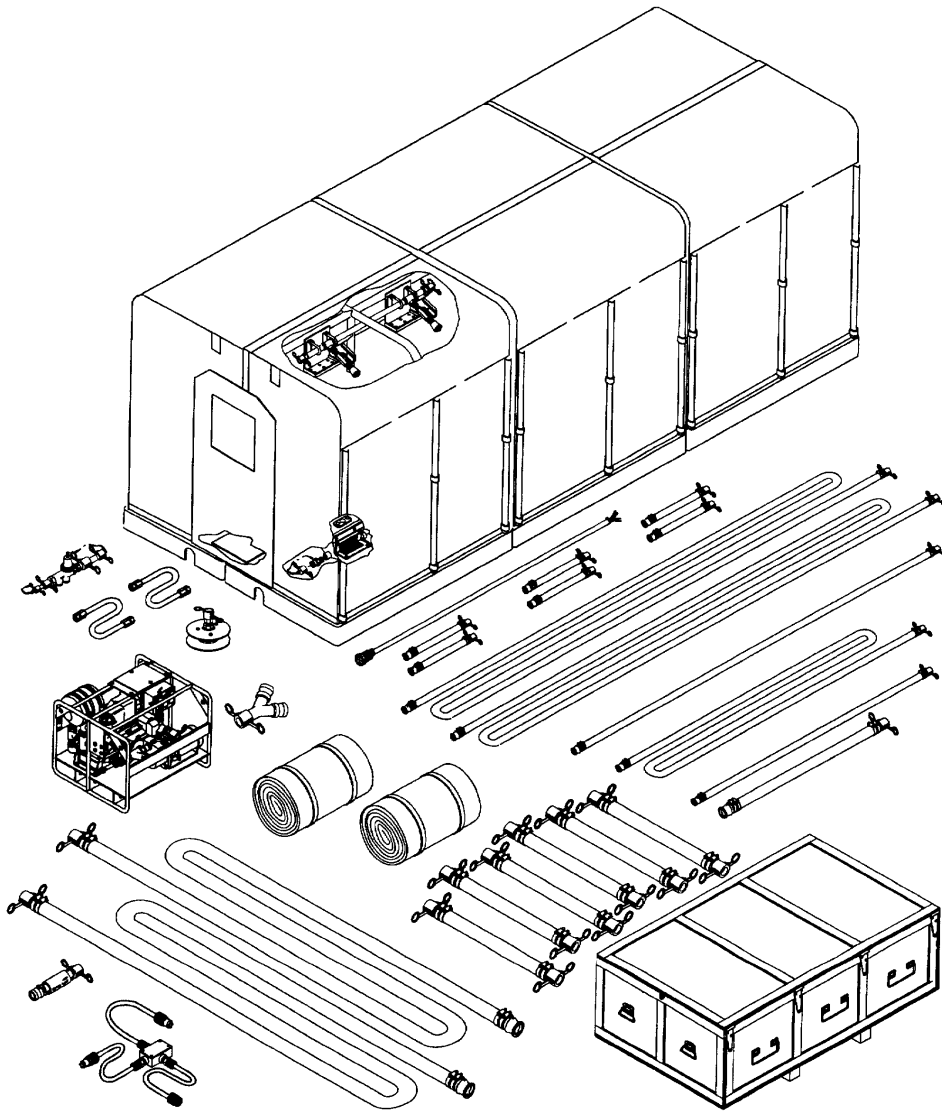

Figure 1-1. Portable Shower Module

CHAPTER 1 INTRODUCTION

SECTION I GENERAL INFORMATION

1.1. SCOPE.

This manual covers operator's, unit, direct support and general support maintenance of the SHOWER-1, portable shower module. The portable shower module provides six two-person showers stalls for field personnel.

1.2. MAINTENANCE FORMS, RECORDS AND REPORTS.

Department of the Army forms and procedures used for equipment maintenance will be those prescribed by DA Pam 378-750, (The Army Maintenance Management System).

1.3. DESTRUCTION OF ARMY MATERIAL TO PREVENT ENEMY USE.

Refer to TM 750-244 for specific instructions on the destruction of army equipment to prevent enemy use.

1.4. PREPARATION FOR STORAGE OR SHIPMENT.

Refer to chapter 4 of this manual for package, storage, and shipment instructions.

1.5. QUALITY ASSURANCE.

Requirement for specific quality assurance steps are not applicable to this equipment.

1.6. REPORTING EQUIPMENT IMPROVEMENT RECOMMENDATIONS (EIR).

If your portable shower module needs improvements, let us know. Send us an EIR. You, the user, are the only one who can tell us what you don't like about your equipment. Let us know what you don't like the design or performance. Put it on an SF 368 (Quality Deficiency Report). Mail to us at: Commander, U.S. Army Soldier Systems Command, ATT: AMSSB-RIM-E(N), Kansas Street, Natick MA 01760-5052.

1.7. WARNING INFORMATION.

The portable shower module is warranted for 365 days from the date of shipment from Keco Industries. Report all defects to your supervisor, who will take appropriate action.

1.8. CORROSION PREVENTION AND CONTROL (CPC).

It is important to report any corrosion problems with this item so the problem can be corrected and improvements made to prevent it in future items. While corrosion is typically associated with rusting of metals, it can also include deterioration of other materials, such as rubber and plastic. Unusual cracking, softening, swelling, or breaking of these materials may be a corrosion problem. If you find a corrosion problem, report it on an SF 368, (Product Quality Deficiency Report). Using key words like corrosion, rust, deterioration, or cracking will help ensure identification as a CPC problem. Submit the form to the address specified in DA Pam 738-750.

SECTION II EQUIPMENT DESCRIPTION AND DATA

1.9. CHARACTERISTICS, CAPABILITIES, AND FRATURES.

1.9.1. The Keco model SHOWER-1 is made up of six two-person shower stalls. Each shower stall base uses a frame assembly, with shower heads attached, to support a cover assembly. The six shower stalls strips are joined to make a 12 person walk-through shower facility. Door panels, secured using hook-and-pile fasteners strips, are provided on the two open ends of the facility.

1.9.2. Water supply and draining is provided by an electric pump assembly.

1.9.3. Typical installation of the portable shower module is inside a temper tent with four three-person shave stands. Heated water for the portable shower module and shave stands is provided by a portable hot water system.

1.9.4. The portable shower module is limited to use only in environments where the ambient air temperature is above 32degrees Fahrenheit (0 degrees centigrade).

1.10. LOCATION AND DESCRIPTION OF MAJOR COMPONENTS. Refer to Figure 1-2.

Shower Stall (1).

Pump Assembly (2).

Hoses and Fittings (3).

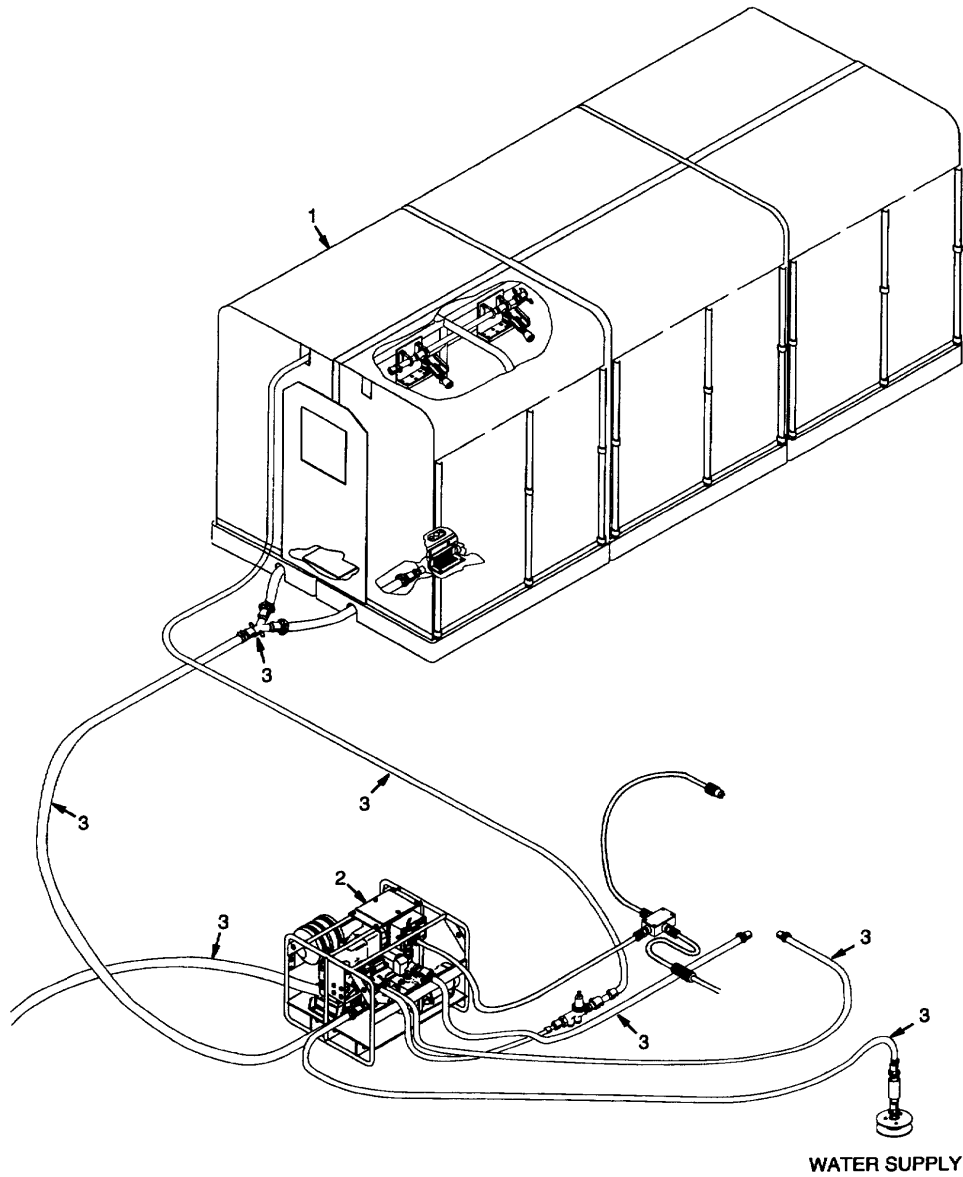

Figure 1-2. Major Components

1.11. IDENTIFICATION AND DATA PLATE. Refer to figure 1-3.

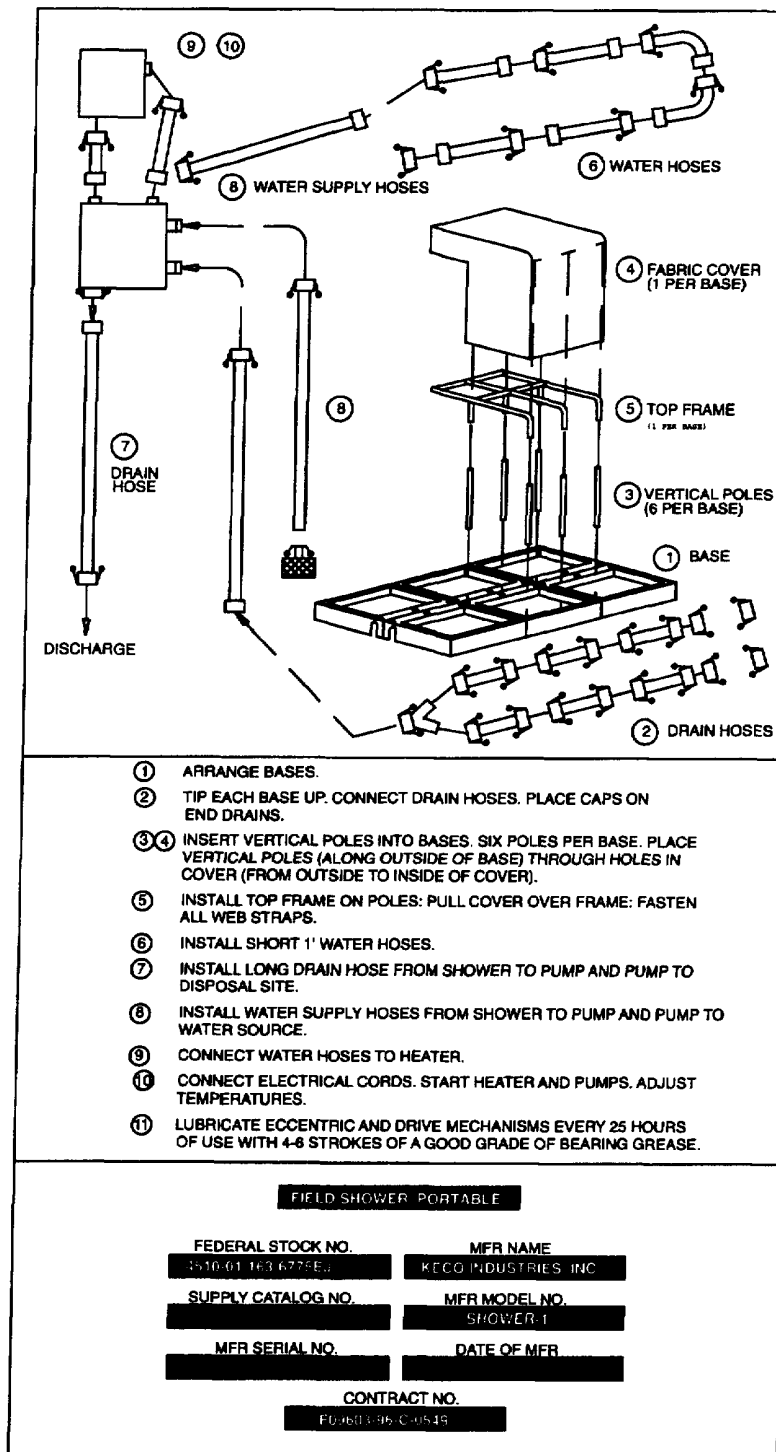

Figure 1-3. Identification Plate

1.12. EQUIPMENT DATA.

Portable Shower Module (six shower stalls)

Dimensions

Width86.00 in. (218.44 cm)
 Height86.38 in. (219.41 cm)
 Length.....216.38 in. (549.61 cm)

Shower Stall

Dimensions

Width43.19 in. (109.70 cm)
 Height86.00 in. (218.44 cm)
 Length.....72.13 in. (183.21 cm)

Pump Assembly

Dimensions

Width32.00 in. (81.28 cm)
 Height26.00 in. (66.04 cm)
 Length.....32.00 in. (81.28 cm)

Power Requirements.....230 vac, 3 phase, 60 hz

Storage Container

Dimensions

Width46.50 in. (118.11 cm)
 Height30.00 in. (76.20 cm)
 Length.....75.50 in. (191.77 cm)

SECTION III PRINCIPLES OF OPERATION

1.13. SUPPLY PUMP.

1.13.1 The supply pump draws water from a clean source and feeds it to the shower head/nozzle inside the shower facility.

1.14. TEMPERATURE REGULATOR

1.14.1. The temperature regulator is manually adjustable to select the supply water temperature. Supply water temperature is controlled by mixing the cold source water with hot water from the portable hot water system.

1.15. SHOWER HEAD.

1.15.1. There are two different shower heads that can be used to provide either a fixed position spray or a swivel type directional spray.

1.16. DIAPHRAGM (DRIAN) PUMP.

1.16.1. The diaphragm pump draws waste/drain water from the shower stall inside the shower facility.

CHAPTER 2 OPERATING INSTRUCTIONS

SECTION I DESCRIPTION AND USE OF OPERATOR'S CONTROL AND INDICATORS

Refer to Figure –21.

2.1. SUPPLY PUMP SWITCH.

The supply pump switch (1) controls power to the supply pump as well as overload protection for the motor. Place the switch in the ON position for operation and the OFF position when not in use. If the motor overloads, the switch will move to a mid-way TRIPPED position and power will be interrupted. If the switch is in the TRIPPED position, it must be switched to OFF then ON to reset it.

2.2. DIAPHRAGM (DRAIN) PUMP SWITCH.

The diaphragm (drain) pump switch (2) control power to the diaphragm (drain) pump as well as providing overload protection for the motor. Place the switch in the ON position and the OFF position when not in use. If the motor overloads, the switch will move to a mid-way TRIPPED position and power will be interrupted. If the switch is in the TRIPPED position, it must be switched to OFF then ON to reset it.

2.3. TEMPERATURE REGULATOR.

The temperature regulator (3) has a manually adjusted control knob that can be set to deliver the desired water temperature to the shower stall. Turning the control knob counterclockwise increases the delivered water temperature and clockwise decreases it.

2.4. TEMPERATURE GAUGE.

The temperature gauge (4) indicates the water temperature being sent to the shower stall. Observe this indicator whenever adjusting the temperature regulator.

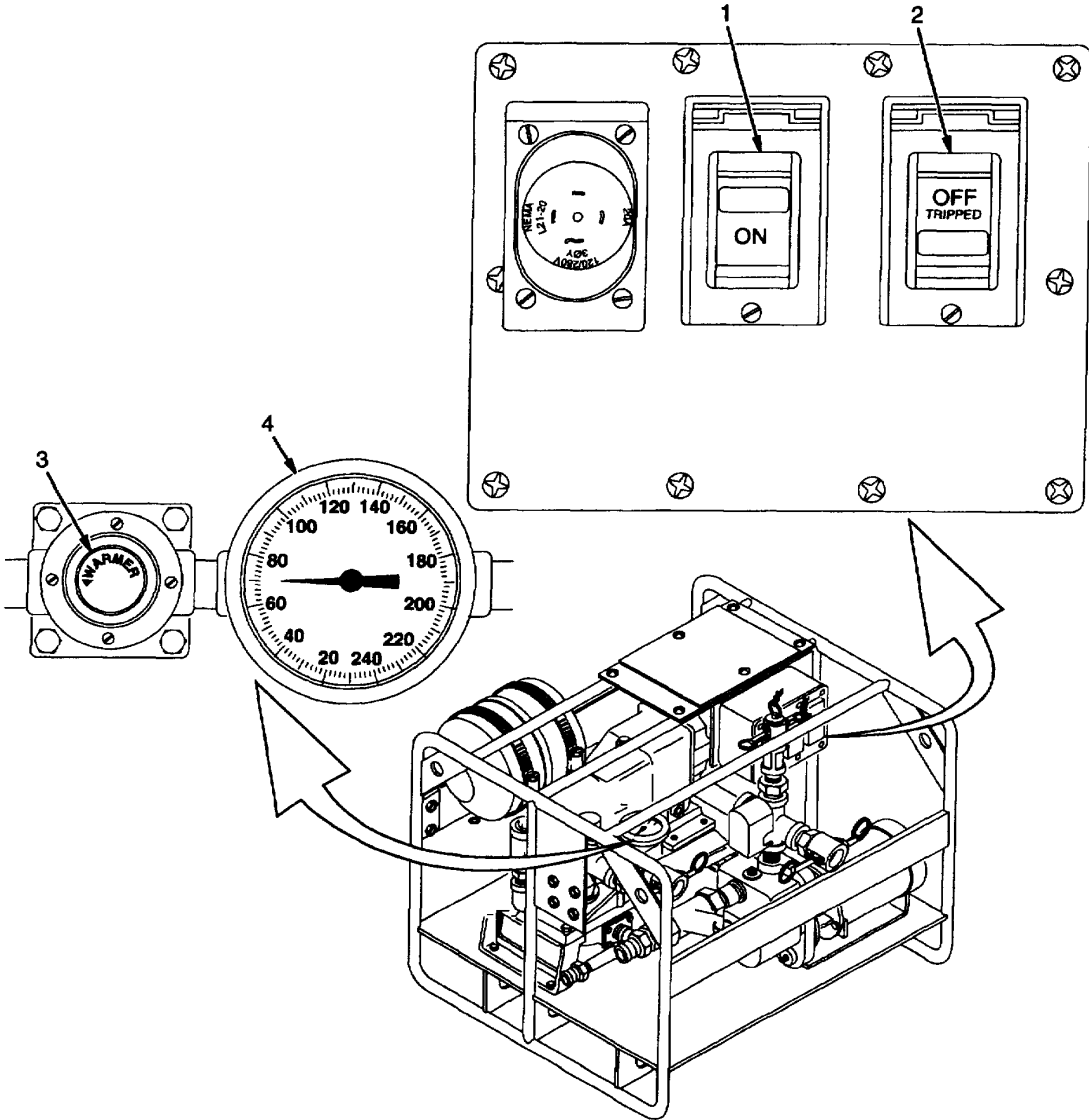

Figure 2-1. Operating Controls and Indicators

SECTION II OPERATOR PREVENTIVE MAINTENANCE CHECKS AND SERVICES (PCMS)

2.5. INTRODUCTION.

2.5.1. General. Preventive Maintenance Checks and Services (PMCS) are essential to the efficient operation of the shower module and to prevent possible damage that might occur through neglect or failure to observe symptoms of a failure in a timely manner. Checks and services performed by operators are limited to those which can be done with minimal disassembly and without the use of tools. The Preventive Maintenance Checks and Services Table 2-1 list the inspections and care of the portable shower module required to keep it in good operating condition.

2.5.1.1. Perform your BEFORE (B) PMCS before you operate the portable shower module for the first time each day. These do not need to be performed before each use of the facility during the day.

2.5.1.2. Perform your DURING (D) PMCS while the portable shower module has been used for the day.

2.5.1.3. Perform your AFTER (A) PMCS after the portable shower module has been used for the day.

2.5.1.4. If a fault is discovered while performing your PMCS, correct it if possible. If the fault cannot be corrected, use DA Form 2404 (Equipment Inspection and Maintenance Worksheet) to record the fault and immediately report it to your supervisor. When completing DA Form 2404, be sure to reference the item number of the faulty item from Table 2-1.

2.5.2. PMCS Procedures. The following is a description of each column found in Table 2-1.

2.5.2.1. Item Number Columns. Indicates each procedure in consecutive order.

2.5.2.2. Interval Column. Indicates when the item is to be checked or serviced.

2.5.2.3. Location/Item to be Checked or Serviced Column. Indicates the item by name and identification where it can be found in the system.

2.5.2.4. Procedure Column. Lists the procedures required to perform a check or service on the item.

2.5.2.5. Not Fully Mission Capable if: Column. Identifies any specific condition that would prevent the system from being used.

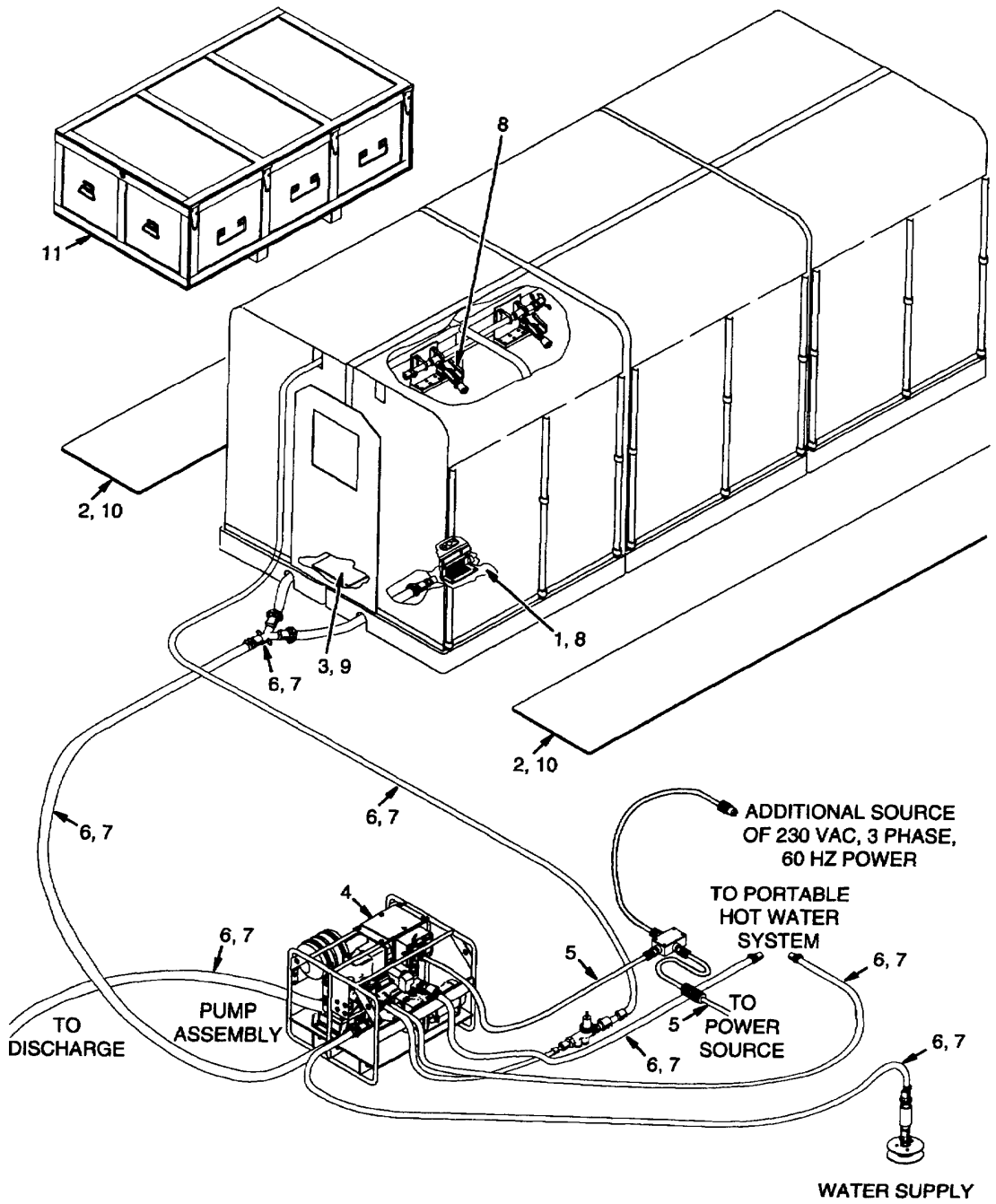

Figure 2-2. Operator's PMCS Routing Diagram

Table 2-1. Operator Preventive Maintenance Checks and Services for SHOWER-1

Item No.	Interval	<u>Location</u>	Procedure	Not Fully Mission Capable If:
		Item to be Checked or Serviced		
1	Before	Shower Facility	<p>Check that rain grate is not obstructed. Clear obstruction.</p> <p>Check surfaces for soap or dirt buildup. Clean if necessary using a bristle brush.</p>	Drain grate is obstructed.
		Portable Shower Base		
2	Before	Floor Mat	Check that floor mat is laying flat and is not cut or damaged. If not laying flat, straighten it. Replace if damaged.	
3	Before	Floor Panel	<p>Check that floor panels are not loose, cut or damaged. Secure if loose, replace if damaged.</p> <p>Check for soap or dirt buildup. Clean if necessary using a bristle brush.</p>	
		Pump Assembly		
4	Before	Pump Assembly	Check for dirt buildup. Clean if necessary.	
5	Before	System Power Cable	Check that system power cable is in good condition and securely connected to pump assembly and input power cable. Secure if loose or notify unit maintenance if damaged.	System power cable is damaged or loose on pump assembly or input power cable.

Table 2-1. Operator Preventive Maintenance Checks and Services for SHOWER-1- Continued

Item No.	Interval	Location	Procedure	Not Fully Mission Capable If:
		Item to be Checked or Serviced		
6	Before	<u>Interconnection System</u> Hoses and Fittings	<p>Check that all hoses and fittings are properly connected and secure. Notify supervisor if loose or improperly connected.</p> <p>Check that hoses are not kinked, pinched, or damaged. Move hoses as necessary to relieve kink or pinch. Notify supervisor if damaged.</p> <p>Inspect strainer for debris or obstruction. Clear any obstruction found.</p>	<p>A hose or fitting is loose or improperly connected.</p> <p>A hose is kinked, pinched, or damaged.</p> <p>Strainer or drain hose obstruction.</p>
		<u>Interconnection System</u> Hoses and Fittings	<p>Inspect all hoses and fittings for leaks. If leak is found, take appropriate action indicated in leakage definition.</p> <p>Inspection strainer for debris or obstruction. Clear and obstruction found. If water supply is contaminated, notify supervisor.</p> <p>Inspect drain hose for obstruction. Clear any obstruction found.</p>	<p>Strain of drain hose obstruction.</p>

Table 2-1. Operator Preventive Maintenance Checks and Services for SHOWER-1 – Continued

Item No.	Interval	Location	Procedure	Not Fully Mission Capable If:
		Item to be Checked or Serviced		
8	After	<u>Shower Facility</u>		
		Portable Shower Base	Using a bristle brush, scrub brush base to remove soap buildup. Open showerheads and allow water to run until water leaving drain hose is clear. Shut off supply and diaphragm (drain) pumps.	
		Floor Panel	Using a bristle brush, scrub floor panel to remove soap buildup. Rinse with clear water.	
9	After	Floor Panel	Using a bristle brush, scrub floor panel to remove soap buildup. Rinse with clear water.	
10	After	Floor Mat	Using a bristle brush, scrub floor mat to remove any dirt. Rinse with water.	
11	After	Storage Container	Check for damage or missing hardware and any damage to container.	Container damage or hardware missing.

SECTION III OPERATION UNDER USUAL CONDITIONS

2.6 ASSEMBLY AND PREPARATION FOR USE.

The portable shower module is shipped disassembled with parts in six storage containers. The pump assembly is the only item shipped loose. Table 2-2 lists the content of each storage container.

2.6.1. Site Selection. The portable shower module should be assembled on a site that is as level as possible and well drained. The portable shower module must be near an electrical power source, clean water source, and wastewater disposal site. If these items are not available, they must be provided before assembly. Carefully review the assembly instructions to determine the optimum location for connection to these systems.

Table 2-2. Storage Container Contents

STORAGE CONTAINER 1		STORAGE CONTAINER 4	
Description of Contents	Quantity	Description of Contents	Quantity
Shower Base	1	Shower Base	1
Top Frame Assembly	1	Top Frame Assembly	1
Vertical Support	6	Vertical Support	6
Shower Cover	1	Shower Cover	1
2 inch Drain Hose (5 feet long)	1	2 inch Drain Hose (5 feet long)	1
1 ½ inch Supply Hose (35 feet long)	1	1 inch Supply Hose (12 feet floor Mat)	1
2 inch Drain Hose	1	Floor Mat	2
Regulator Valve assembly	1	Clinching Straps (2 on each floor mat)	4
STORAGE CONTAINER 2		STORAGE CONTAINER 5	
Description of Contents	Quantity	Description of Contents	Quantity
Shower Base	1	Shower Base	1
Top frame assembly	1	Top Frame Assembly	1
Vertical Support	6	Vertical Support	6
Shower Cover	1	Shower cover	1
2 inch Drain Hose (5feet long)	1	2 inch Drain Hose (5feet long)	1
1 inch Supply Hose (25 feet long)	1	1 inch Supply Hose (35 feet long)	1
Y-Fitting Coupler	1	Water Supply Strainer	1
Shower Heads (alternate)	12	System Power Cable Assembly	1
STORAGE CONTAINER 3		Input Power Cable Assembly	1
Description of Contents	Quantity	Spring Check Valve assembly	1
Shower Base	1	STORAGE CONTAINER 4	
Top frame Assembly	1	Description of Contents	Quantity
Vertical Support	6	Shower Base	1
Shower Cover	1	Top Frame Assembly	1
2 inch Drain Hose (5 feet long)	1	Vertical Support	6
1 inch Supply Hose (7.5 feet long)	1	Shower Cover	1
2 inch Drain Hose (35 feet long)	3	2 inch Drain Hose (5 feet long)	1
Floor Panels	3	1 inch Supply Hoses (2 feet long)	6
Door Panels	2	1 inch Supply Hose (35 feet long)	1
		Fuel Hose Assemblies	2

Refer to figure 2-3.

2.6.1. Component Placement.

NOTE

The following is only a suggested layout of supplied components and may differ from that required for any specific installation.

Three personnel required for assembly.

- a. Remove components from storage containers and organize them by size and length to aid assembly. Be sure to place components away from assembly area. When removing shower base (1), place them in assembly area and arrange them as shown. If any components are damaged, notify supervisor.
- b. Place all packaging material into storage containers then move containers to a suitable storage site.
- c. Remove two clinching straps from each floor mat (2). Unroll and position as shown.
- d. Position the pump assembly (3) and portable hot water system (4) (not provided) as shown. Refer to any documentation covering the portable hot water system to find specific installation requirements for it.

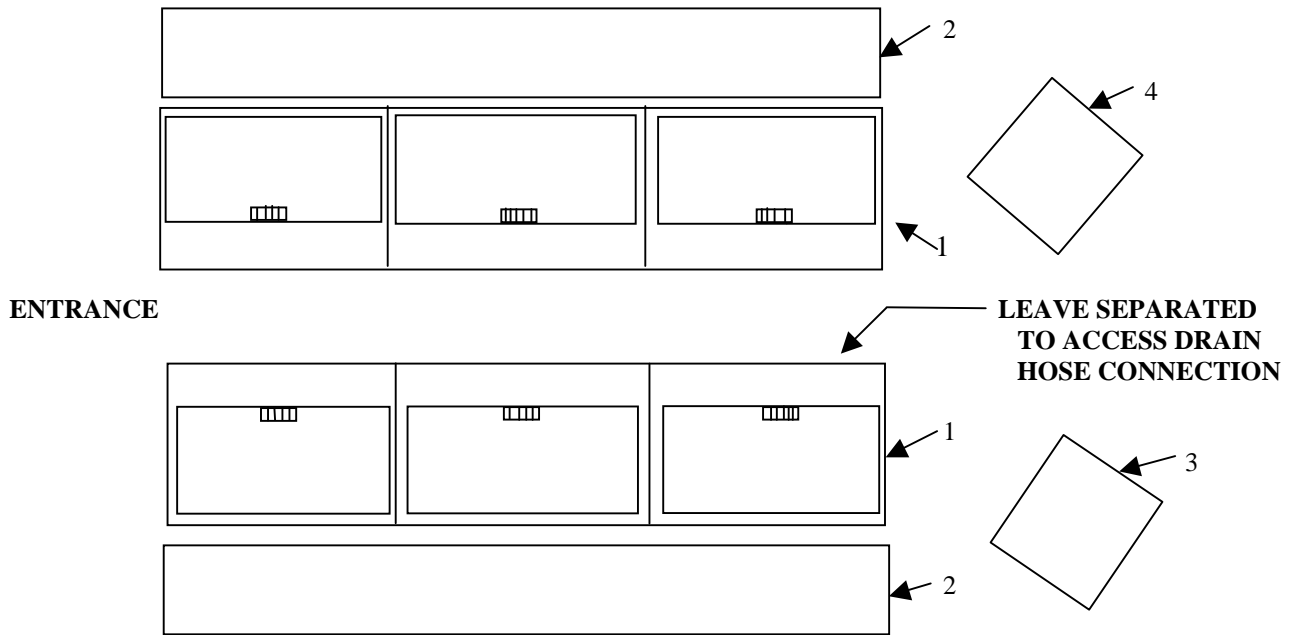

Figure 2-3. Component Placement

Refer to figure 2-4.

2.6.3. Shower Facility Assembly.

NOTE

To install drain hose assembly, reach through access holes in base to Connect hose ends or raise the shower bases. Use either method you Find more convenient.

- a. Install six drain hose assemblies (1) (2 inch diameter X5 feet long). Be sure that two hoses extend out of shower facility toward pump assembly.
- b. Install two caps (2) in end of shower bases (3) away from pump assembly.

CAUTION

Loose caps can get wedged under shower basing damage to the base.

- c. If shower bases (3) were raised for hose connection, carefully lower them together. Push bases together into final position. Be sure loose caps (4) are not wedged under base.
- d. Install three floor panels (5) and secure to shower bases (3) using attached hook and pile fastener strips.

NOTE

The following procedures are typical for each shower base.

- e. Install five vertical supports (6) into Shower base (3). Note that outer center vertical support is not installed at this time.
- f. Place shower cover (7) over top frame assembly (8) and carefully guide three outer legs through openings in back of cover. Secure shower cover to top frame assembly using attached hook and pile fastener strips (9).
- g. From the inside, lift top frame assembly (8), with shower over (7) attached, and install onto vertical supports (6). Note that the two outer supports are on the outside of cover.
- h. Install outer center vertical support (10).
- i. Secure shower cover (7) to vertical supports (6 and 10) using attached hook and pile fastener strips (11).
- j. Secure shower cover (7) to inside shower base (3) using attached hook and pile fastener strips.
- k. Repeat above steps to assemble remaining shower stalls.
- l. Secure fastening top frame assemblies (7) to each other using attached hook and pile fastener strips (12).
- m. Secure facing shower covers (7) to each other using attached hook and pile fastener strips.
- n. Secure two door panels (13) to outside of assembled shower facility using attached hook and pile fastener strips.

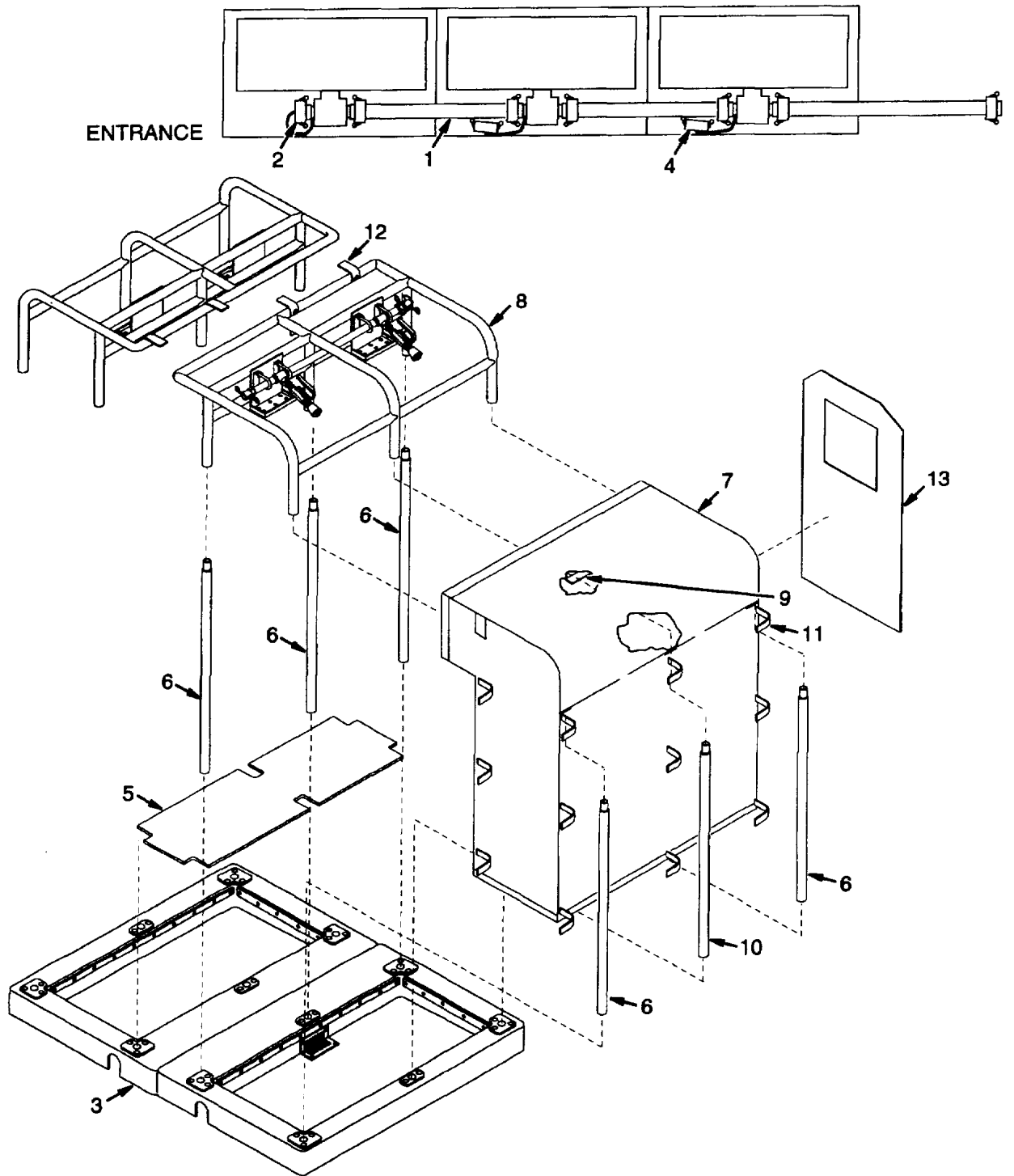

Figure 2-4. Shower Facility Assembly

Refer to Figure 2-5.

2.6.4. Hose Connections.

- a. If using natural or open water source, assemble water supply strainer (1) and spring check valve assembly (2). Note that flow direction of check valve is away from strainer.
- b. Connect supply hose (3) (1 inch diameter X 35 feet long) to spring check valve assembly (2) if using natural or open water source, or to closed water supply connection point. If using natural or open water source, position hose with supply strainer (1) into water so that strainer is completely submerged. If using a closed water supply, be sure supply valve is closed.
- c. If needed to reach pump assembly (4), connect supply hose (5) (1 inch diameter X 25 feet long) to supply hose (3).
- d. Connect supply hose (3 or 5) to supply pump inlet (6).
- e. Connect supply hose (7) between temperature regulator outlet (8) and regulator valve assembly (9) inlet. Note that flow direction of regulator valve is away from pump assembly.
- f. Connect supply hose (10) (1 inch diameter X 35 feet long) between regulator valve assembly (9) outlet and showerhead manifold assembly (11). Note that supply hose passes through opening in shower cover.
- g. Connect six supply hoses (12) between each showerhead manifold assembly (11) as shown. Connect supply hose ends together over entrance to shower facility away from pump assembly to form a crossover pipe. Note that supply hose pass through opening in shower cover.
- h. Install attached cap (13) onto open end of last showerhead manifold assembly.
- i. Connect two drain hose (14) onto Y-fitting coupler (15).
- j. Connect drain hose (16) (2 inch diameter X 35 feet long) between Y-fitting coupler (15) and diaphragm (drain) pump inlet (7).
- k. Connect drain hose (18) to diaphragm (drain) pump outlet (19). Connect opposite end of hose to waste water connection point (storage tank) or route to waste water disposal site.
- l. Connect supply hose (20) (1 ½ inch diameter X 5 feet long) to supply pump outlet (21).
- m. Connect supply hose (22) (1 inch diameter X 12 feet long) to hot water inlet (23).
- n. Connect supply hoses (20 and 22) to portable hot water system (24). Refer to technical manual covering the portable hot water system to find specific connection requirements for it.
- o. Notify unit maintenance to connect two fuel hoses (25) to portable hot water system (24). Refer to technical manual covering the portable hot water system to find specific connection requirements for it.

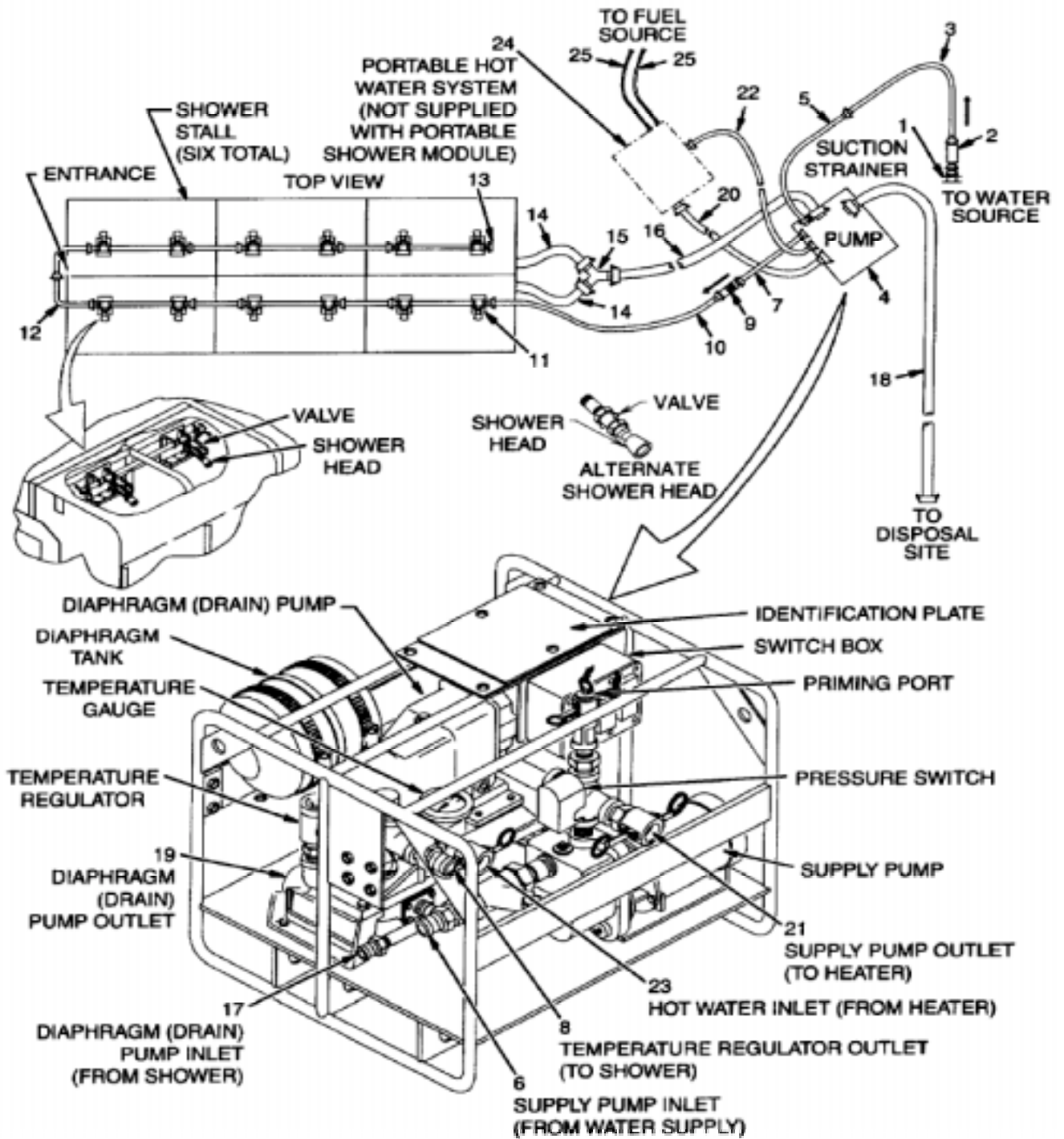

Figure 2-5. Hose Connections

2.6.5. Electrical Connection

WARNING

High voltage is used in the portable shower module. Care must be taken to Avoid personal injury or death from energizing circuits.

- a. Check that both pump assembly switches are in the OFF position then connect either the short (4 feet) or long (10 feet) system power cable assembly plug to the pump assembly input power connector.
- b. Connect system power cable assembly connector to input power cable assembly plug.
- c. Notify unit maintenance to connect input power cable assembly to a source of 230 vac, 3phase, 60 hz power.

2.7. OPERATING PROCEDURES

2.7.1. Start up Procedures.

- a. Check that all accessible hose and power connections are secure.
- b. Check that supply hose is connected to a closed water supply or that the supply strainer is completely submerged in a natural or open water source, whichever is applicable.
- c. Check that the drain hose is routed to a waste water disposal site or connected to a waste water connection point (storage tank), whichever is applicable.
- d. Open all shower nozzle valves. If connected to a closed water supply, open supply valve.
- e. Energize power source then place both pump assembly switches to the ON position.
- f. Allow water to flow through system for 2 minutes then close all shower nozzle valves. Supply and diaphragm (drain) pumps should stop automatically when system pressure builds up.
- g. Check pump assembly and all accessible hose and connections for evidence of leaking. Notify supervisor if a leak is found.
- h. Start-up the portable hot water system and wait for t to reach operating temperature. Refer to technical manual covering the portable hot water system to find specific operating procedures.
- i. When portable water system has reached operating temperature, open all shower nozzle valves and monitor the pump assemble temperature gauge. Adjust the temperature regulator as necessary to maintain desired shower water temperature. When desired temperature is ready, close all shower nozzle valves. The shower facility is now ready for use.

2.7.2. Operating Procedures. Open shower nozzle valve as necessary for desired water flow. When finished with shower, close shower nozzle valve.

2.7.3. Shut down Procedures.

- a. Shut-down the portable hot water system. Refer to technical manual covering the portable hot water system to find specific operating procedures.
- b. Place both pump assembly switches to the OFF position and de-energize power source.
- c. If connected to a closed water supply, close water supply valve.
- d. Open a shower nozzle valve to relieve system pressure. Close valve when water stops flowing from nozzle.

SECTION IV OPERATION UNDER UNUSUAL CONDITIONS

The portable shower module is typically installed inside a temper tent and is therefore not subjected to any unusual operating conditions. It should be noted that the portable shower module is limited to use in environments where the ambient air temperature is above 32 degrees F. (0 degrees C).

THIS PAGE INTENTIONALLY LEFT BLANK

CHAPTER 3 OPERATOR MAINTENANCE INSTRUCTIONS

SECTION I LUBRICATION INSTRUCTIONS

Lubrication is not required at this maintenance level.

SECTION II OPERATOR TROUBLESHOOTING PROCEDURES

This section cannot list all the possible malfunctions that may occur with the equipment. If a malfunction occurs that is not listed or actions listed do not correct a malfunction, notify your supervisor.

Table 3-1. Operator Troubleshooting

MALFUNCTION 1. NO WATER AT SHOWER.

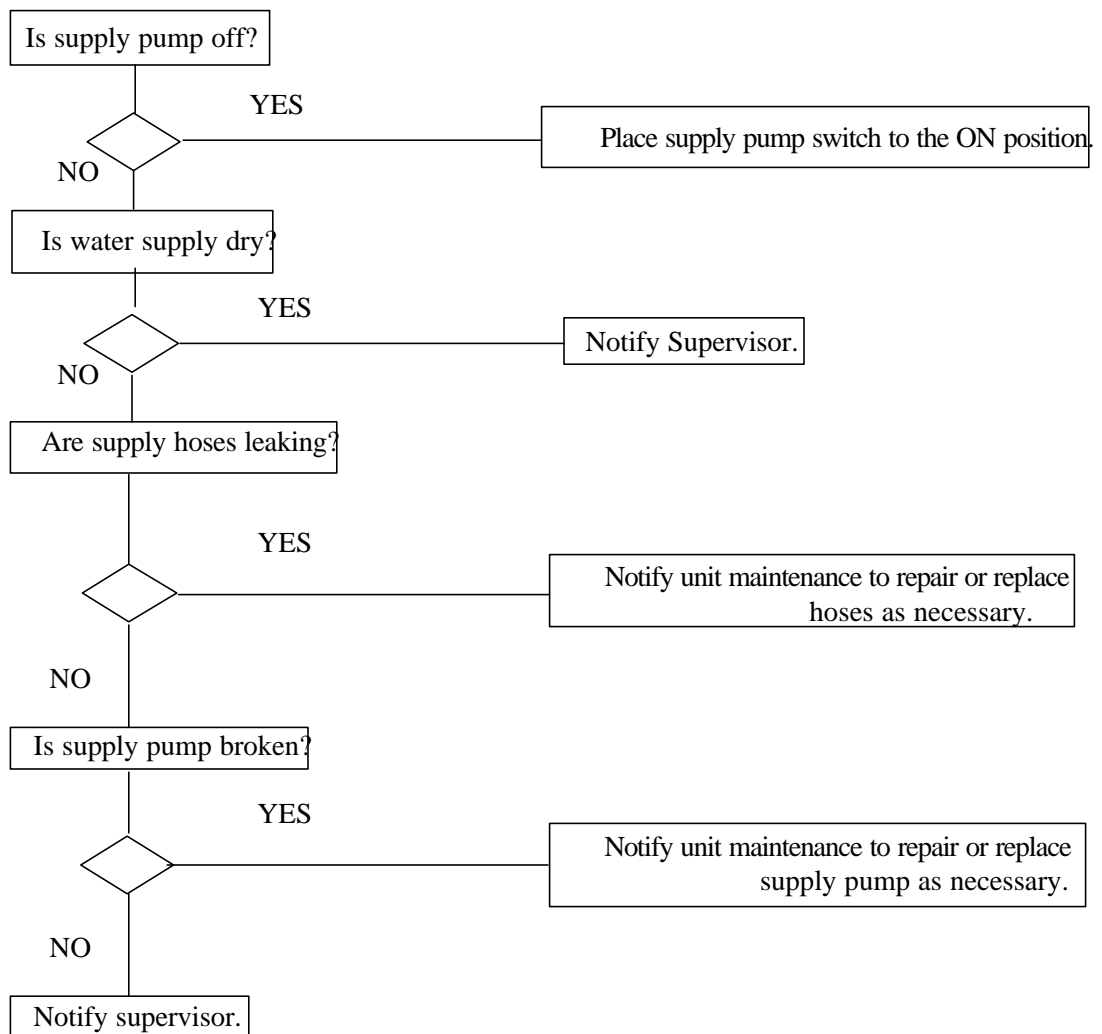

Table 3-1. Operator Troubleshooting - Continued

MALFUNCTION 2. WATER DOES NOT DRAIN.

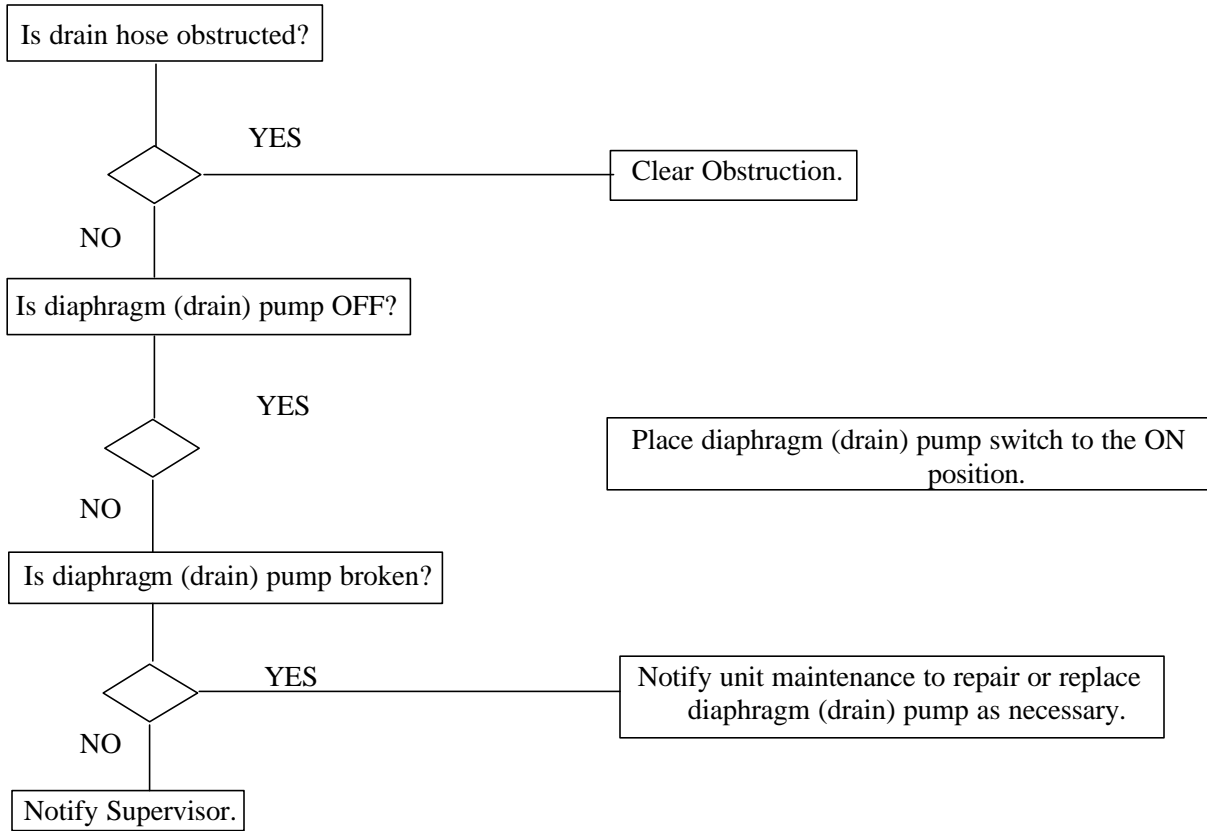
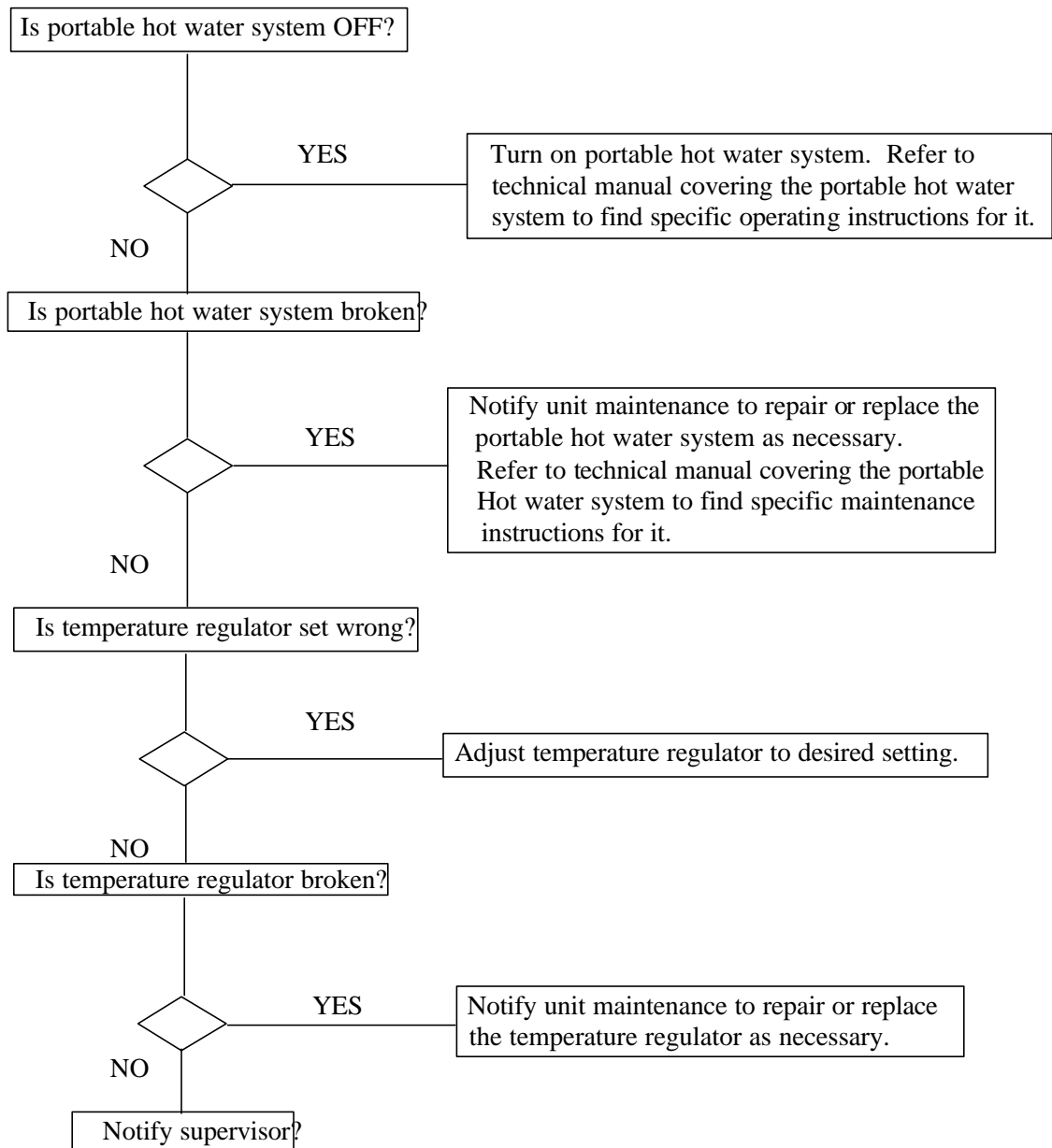

Table 3-1. Operator Troubleshooting – Continued.

MALFUNCTION 3. WATER TEMPERATURE INCORRECT.



SECTION III OPERATOR MAINTENANCE PROCEDURES

3.1. Y-FITTING COUPLER REPLACEMENT.

This task covers: a. Removal b. Installation

INITIAL SETUP

Equipment Conditions:

Shower facility not in use.
Both pump assembly switches in the OFF position,
Paragraph 2.7.

Refer to figure 3-1.

- a. Removal. Release quick disconnect coupling (1) and separate drain hoses (2) from Y-fitting coupler (3).
- b. Installation. Connect drain hoses (2) to Y-fitting coupler (3) and secure using quick disconnect couplings (1).

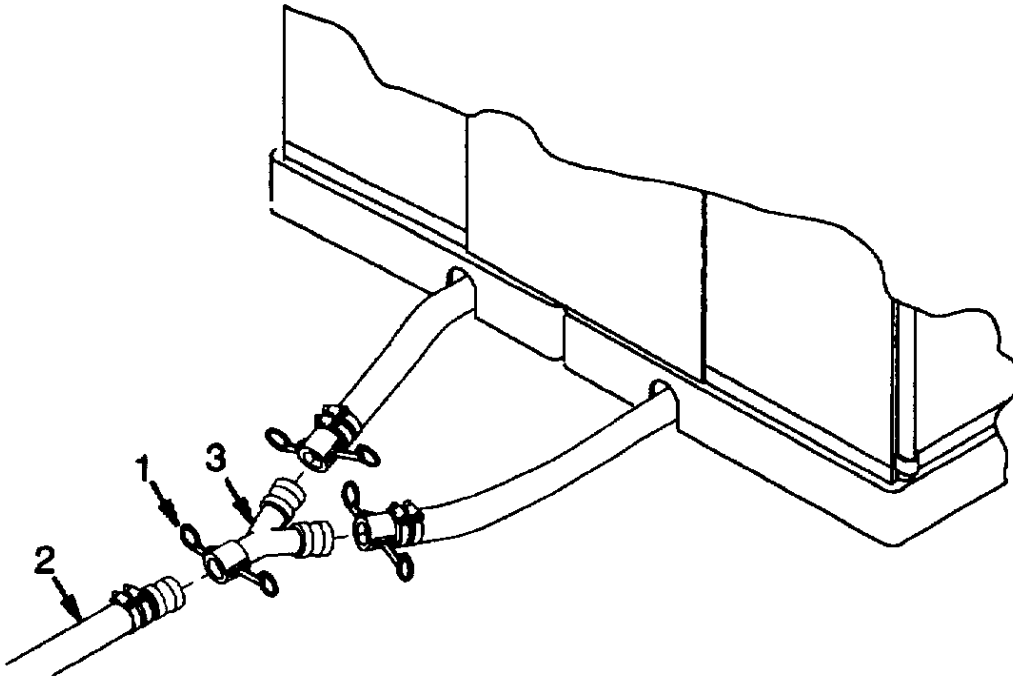

Figure 3-1. Y-fitting Coupler

3.2. DOOR PANEL REPLACEMENT.

This task covers: a. Removal b. Installation

INITIAL SETUP

Equipment Conditions:

Shower facility not in use.

Refer to figure 3-2.

- a. Removal. Remove door panel (1) by separating hook and pile fastener strip (2).
- b. Installation. Install door panel (1) and secure using hook and pile fastener strip (2).

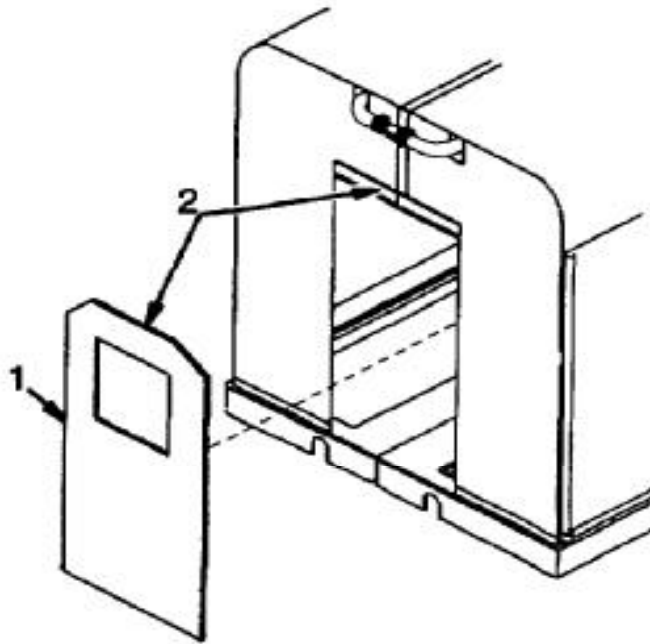

Figure 3-2. Door Panel

3.3. SHOWER COVER REPLACEMENT.

This task covers: a. Removal b. Installation

INITIAL SETUP

Personnel Required:

Three

Equipment Conditions:

Shower Facility not in use.
System shut down and pressure relieved,
paragraph 2.7.

Refer to figure 3-3.

a. Removal.

- (1) Release quick disconnect coupling (s) (1), then separated and remove supply hose (s) (2) as necessary.
- (2) Remove door panel (3) is an end shower cover (4) is being replaced.
- (3) Release hook and pile fastener strips (5) securing shower cover (4) to vertical supports (6 and 7). Remove vertical support (6).
- (4) Release hook and pile strips securing shower cover (4) to shower base (8).
- (5) Release hook and pile fastener strips securing facing shower covers (4) to each other.
- (6) Release pile and fastener strips (9), then from the inside, lift top frame assembly (10) off vertical supports (7) with shower cover (4) attached.
- (7) Release hook and pile fastener strips (11) and remove shower cover (4) from top frame assembly (10).

b. Installation.

- (1) Place shower cover (4) over top frame assembly (10) and carefully guide three outer legs through openings in back of cover. Secure shower cover to top frame assembly with attached hook and pile fastener strips (9).
- (2) From the inside, lift top frame assembly (10), with shower cover (4) attached and install onto vertical supports (7). Note that the two outer supports are on the outside of the cover.
- (3) Install vertical support (6).
- (4) Secure shower cover (4) to vertical supports (6 and 7) using attached hook and pile fastener strips (5).
- (5) Secure shower cover (4) to inside of shower base (8) using attached hook and pile fastener strips.
- (6) Secure facing top frame assemblies (10) to each other using attached hook and pile fastener strips (9)
- (7) Secure facing shower covers (4) to each other using attached hook and pile fastener strips.

- (8) Secure door panel (3), if removed, to outside of shower facility using attached hook and pile fastener strips.
- (9) Install and connect supply hose (s) (2) onto quick disconnect coupling (s) then secure coupling.

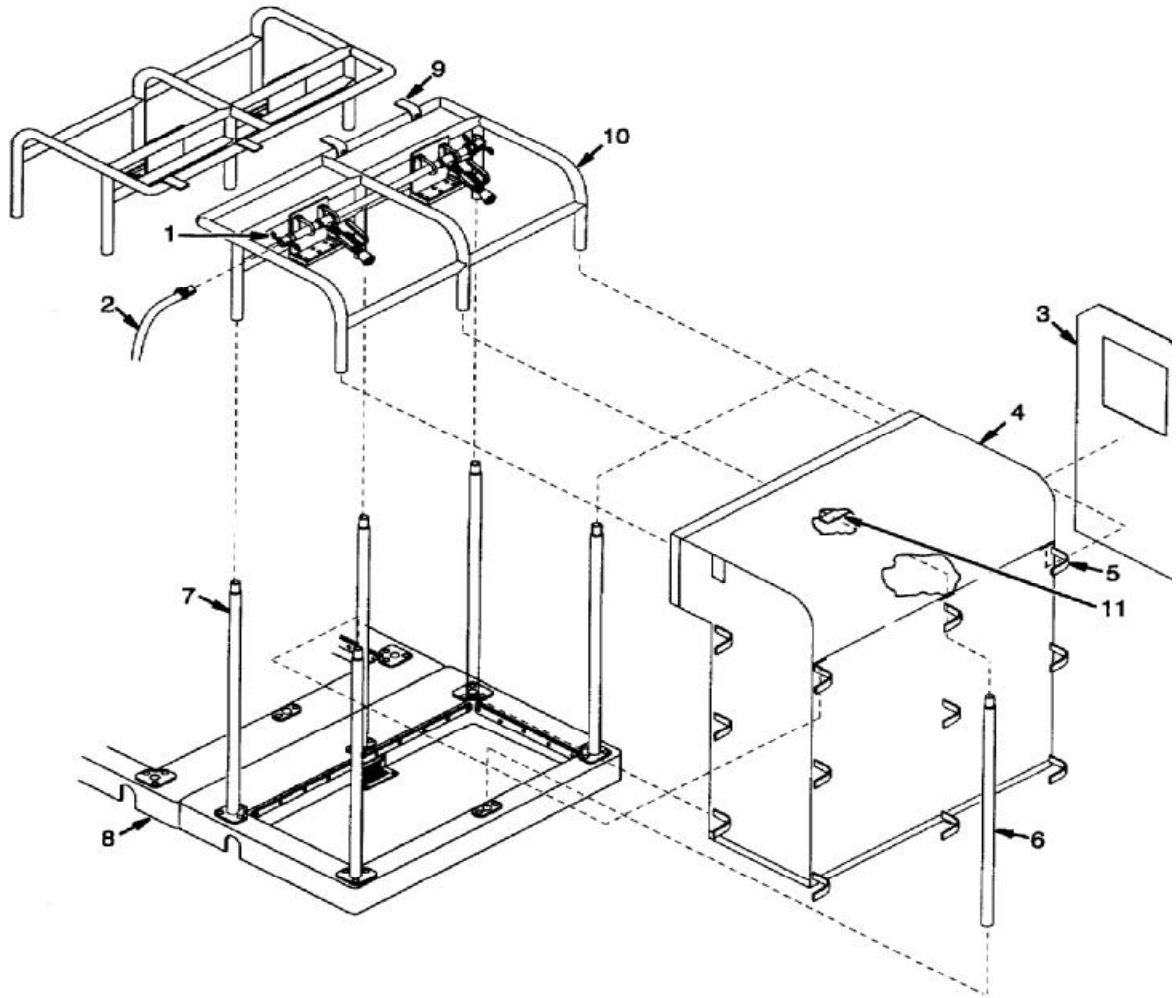

Figure 3-3. Shower Cover

3.4. FLOOR MAT REPLACEMENT.

This task covers: a. Removal b. Installation

INITIAL SETUP

Equipment Conditions:

Shower facility not in use.

Refer to figure 3-4.

- a. Removal. Roll up and remove floor mat (1).
- b. Installation. Remove two clinching straps (2) from floor mat (3). Unroll and position as necessary.

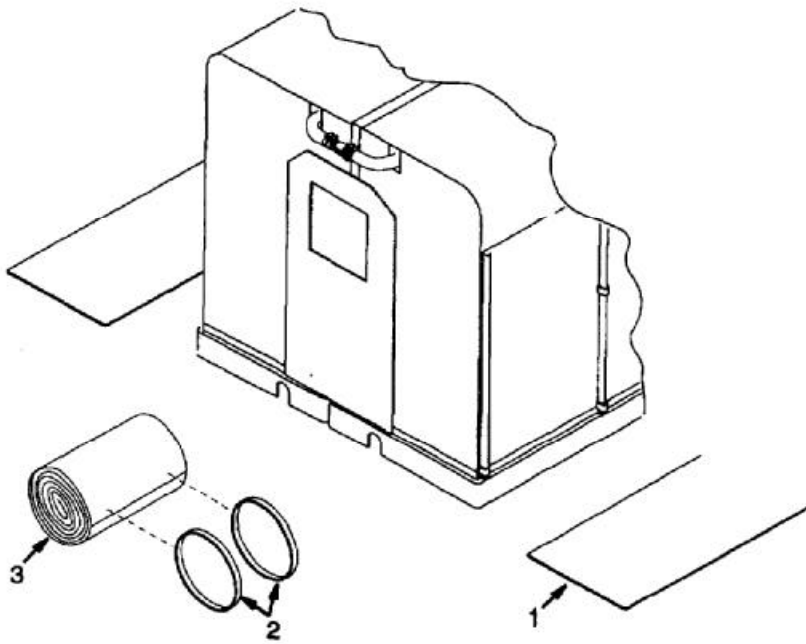

Figure 3-4. Floor Mat

3.5. VERTICAL SUPPORT REPLACEMENT.

This task covers: a. Removal b. Installation

INITIAL SETUP

Equipment Conditions:

Shower facility not in use.

Refer to figure 3-5.

a. Removal.

NOTE

For convenience, replace only one vertical support at a time to a void having
To remove shower cover and top frame assembly.

- (1) Release hook and pole fastener strips securing shower cover (1) to shower base (2).
- (2) Release hook and pile fastener strips (3) from vertical support (4) being removed.
- (3) Lift top frame assembly (5) as necessary and remove vertical support (4).

b. Installation.

- (1) Lift top frame assembly (5) as necessary and install vertical support (4).
- (2) Secure shower cover (1) to vertical support (4) using attached hook and pile fastener strips (3).
- (3) Secure shower cover (1) to inside of shower base (2) using attached hook and pile fastener strips.

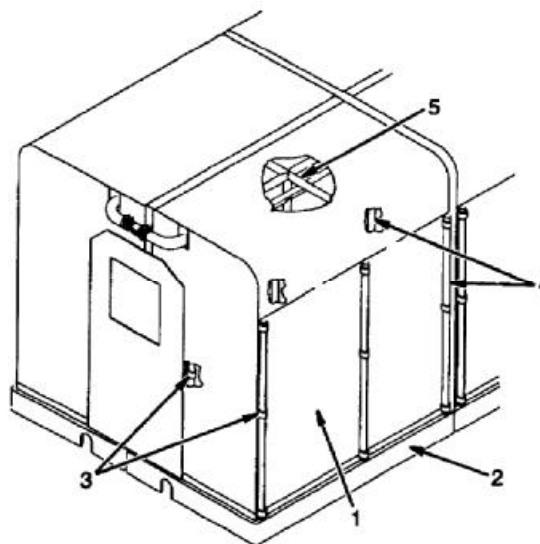

Figure 3-5. Vertical Support

3.6. FLOOR PANEL REPLACEMENT.

This task covers: a. Removal b. Installation

INITIAL SETUP

Equipment Conditions:

Shower facility not in use.

Refer to figure 3-6.

- a. Removal. Release hook and pile fastener strips securing floor panel (1) to shower base (2). Remove floor panel.
- b. Installation. Install floors panel (1) and secure to shower base (2) using attached hook and pile fastener strips.

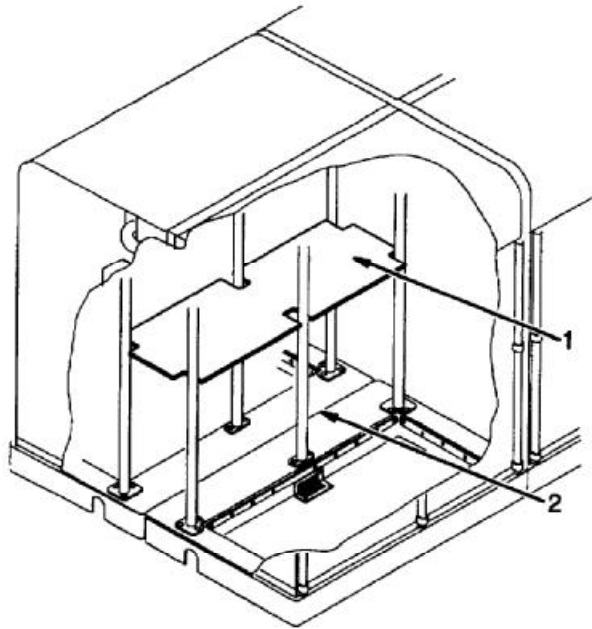

Figure 3-6. Floor Panel

CHAPTER 4 UNIT MAINTENANCE INSTRUCTIONS

SECTION I REPAIR PARTS, TOOLS, TEST, MEASUREMENT, DIAGNOSTIC EQUIPMENT (TMDE), AND SUPPORT EQUIPMENT

4.1. COMMON TOOLS AND EQUIPMENT.

4.1.1. For authorized common tools and equipment, refer to the Modified Table of Organization and Equipment (MTOE), CTA 50-970, or CTA 8-100, as applicable to your unit.

4.1.2. The General Mechanic's Tool Kit (SC 5180-90-CL-N05) will be used for all maintenance tasks. Any additional tools required for an individual maintenance task will be identified in the setup information for that task.

4.2. SPECIAL TOOLS, TMDE, AND SUPPORT EQUIPMENT.

4.2.1. The Repair Parts and Special tools list (RPSTL) (TM10-4510-207-24P) as well as the Maintenance Allocation Chart (MAC) (Appendix B) identify and tools and support equipment needed to maintain the portable shower module.

4.2.2. There are no special or fabricated tools required to maintain the portable shower module.

4.3. REPAIR PARTS.

4.3.1. Any mandatory replacement parts needed for the maintenance tasks are identified in the mandatory replacement parts list located in Appendix G.

4.3.2. Repair parts are listed and illustrated in (TM 10-4510-207-24P) covering unit, DS, and GS maintenance for this equipment.

SECTION II UNIT PREVENTIVE MAINTENANCE CHECKS AND SERVICES (PMCS)

4.4. INTRODUCTION.

4.4.1. General. Preventive Maintenance Checks and Services (PMCS) are essential to the effective operation of the portable shower module and to prevent possible damage that might occur through neglect or failure to observe symptoms of a failure in a timely manner. The Preventive Maintenance Checks and Services Table 4-1 lists the inspections and care of the portable shower module required to keep it in good operating condition.

4.4.1.1 Perform your WEEKLY (W) PMCS once each week, preferably on the same day each week, when the portable shower module is not in use.

4.4.1.2. Perform your MONTHLY (M) PMCS once each month, preferably on the same day each month, when the portable shower module is not in use.

4.4.1.3. Perform your QUARTERLY (Q) PMCS once each three months, preferably at the same part of the month, when the portable shower module is not in use.

4.4.1.4. If a fault is discovered while performing your PMCS, correct it if possible. If the fault cannot be corrected, use DA Form 2404 (Equipment Inspection and Maintenance Worksheet) to record the fault and immediately report it to your supervisor. When completing DA Form 2404, be sure to reference the item number of the faulty item from Table 4-1.

4.4.2. PMCS Procedures. The following is a description of each column found in Table 4-1.

4.4.2.1. Item Number Column. Indicates each procedure in consecutive order.

4.4.2.2. Interval Column. Indicates when the item is to be checked or serviced.

4.4.2.3. Location/Item to be Checked or Serviced Column. Indicates the item by name and identifies where it can be found in the system.

4.4.2.4. Procedure column. Lists the procedures required to perform a check or service on the item.

4.4.2.5. Not Fully Mission Capable if: Column. Identifies any specific condition that would prevent the system from being used.

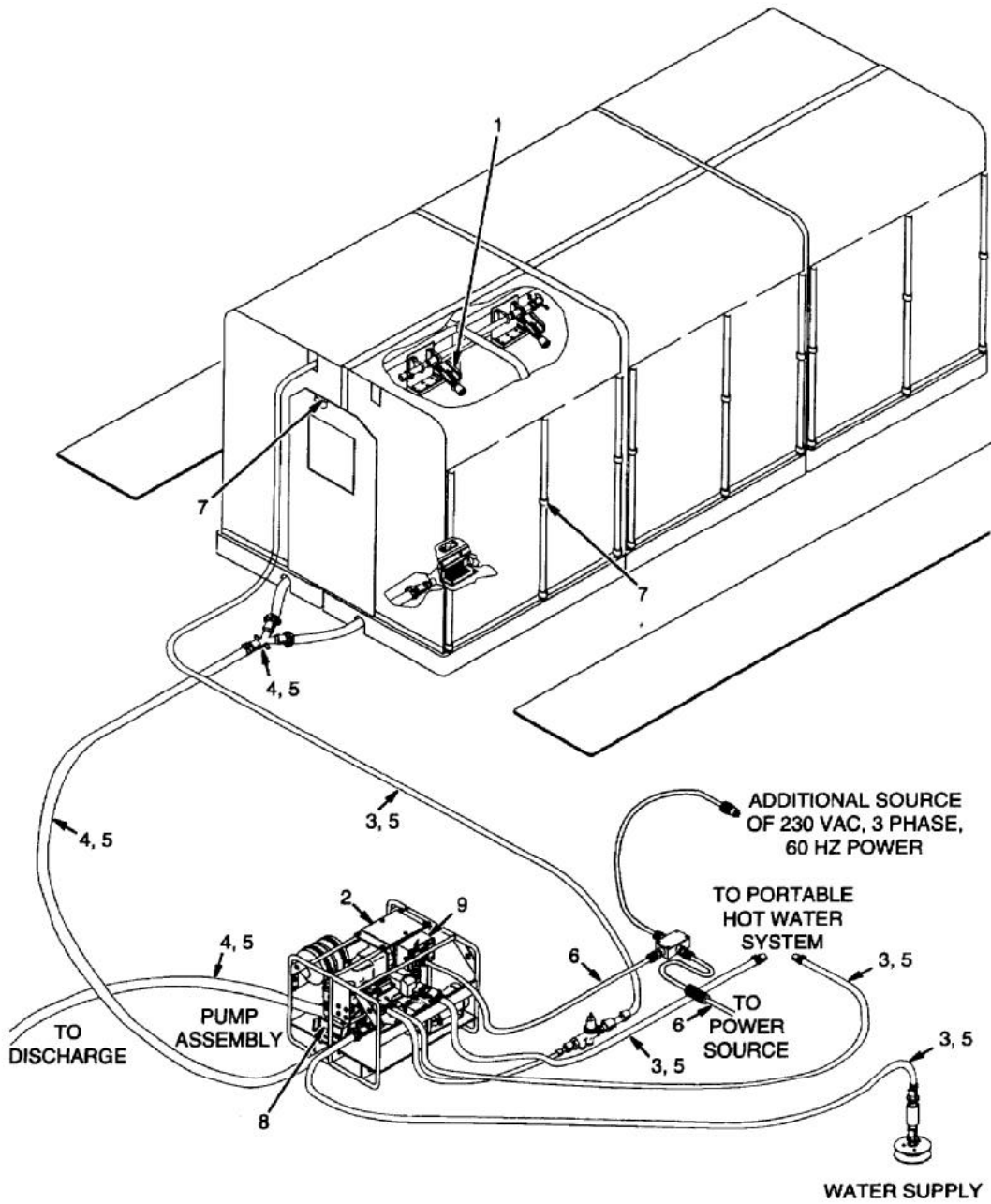

Figure 4-1. Unit's PMCS Routing Diagram

Table 4-1. Unit Preventive Maintenance Checks and Services for SHOWER-1

Item No.	Interval	Location	Procedure	Not Fully Mission Capable If:
		Item to be Checked or Serviced		
1	Weekly	Shower Facility	Operate shower (paragraph 2.7.). Note the operation of each nozzle valve as well as the nozzle spray. If spray is not even, clean the nozzle. If the nozzle cannot be cleaned, replace it (paragraph 4.7). If valve does not operate smoothly, replace it (paragraph 4.7).	Nozzle is clogged or valve does not work smoothly.
		Shower Head Manifold Assembly		
2	Weekly	<u>Pump Assembly</u>	Check pump assembly for leak or damage. Repair as necessary.	Damaged or leaking enough to interfere with operation.
		Pump Assembly		
3	Weekly	<u>Interconnection System</u>	Shut down shower and relieve system pressure (paragraph 2.7). Remove each supply hose one at a time and check for obstructions. Clean as necessary and replace if damaged.	Supply hose is damaged
		Supply Hoses		
4	Weekly	Drain Hoses	Shut down shower (paragraph 2.7). Remove each drain hose one at a time and check for obstructions. Clean as necessary and replace if damaged.	Drain hose is damaged or obstructed.
5	Weekly	Hoses and Fittings	Check all hoses and fittings for damage, leaking, or loose connection. Replace if damaged, repair leaks as necessary, tighten loose connections.	Hose is damaged, loose, or leaking enough to interfere with operation.
6	Weekly	Power Cable Assembly	Check all power cables for damage or loose connection. Replace if damaged and tighten any loose connections.	Power cable is damaged or connection is loose.

Table 4-1. Unit Preventive Maintenance Checks and Services for SHOWER-1 - Continued

Item No.	Interval	Location	Procedure	Not Fully Mission Capable If:
		Item to be Checked or Serviced		
7	Weekly	Shower Facility Hook and Pile Fastener Strips	Check all hook and pile fastener strips for fastening strength. If weak, replace as necessary.	
8	Weekly	<u>Pump Assembly</u> Diaphragm (drain) pump assembly		
9	Quarterly	Switch Box Wiring	Remove switch box cover (paragraph 4.13) and check wiring for damage or loose terminal connections. Replace damaged wires (paragraph 4.13) and tighten terminal connections as necessary.	Wiring is damaged or terminal connections are loose.

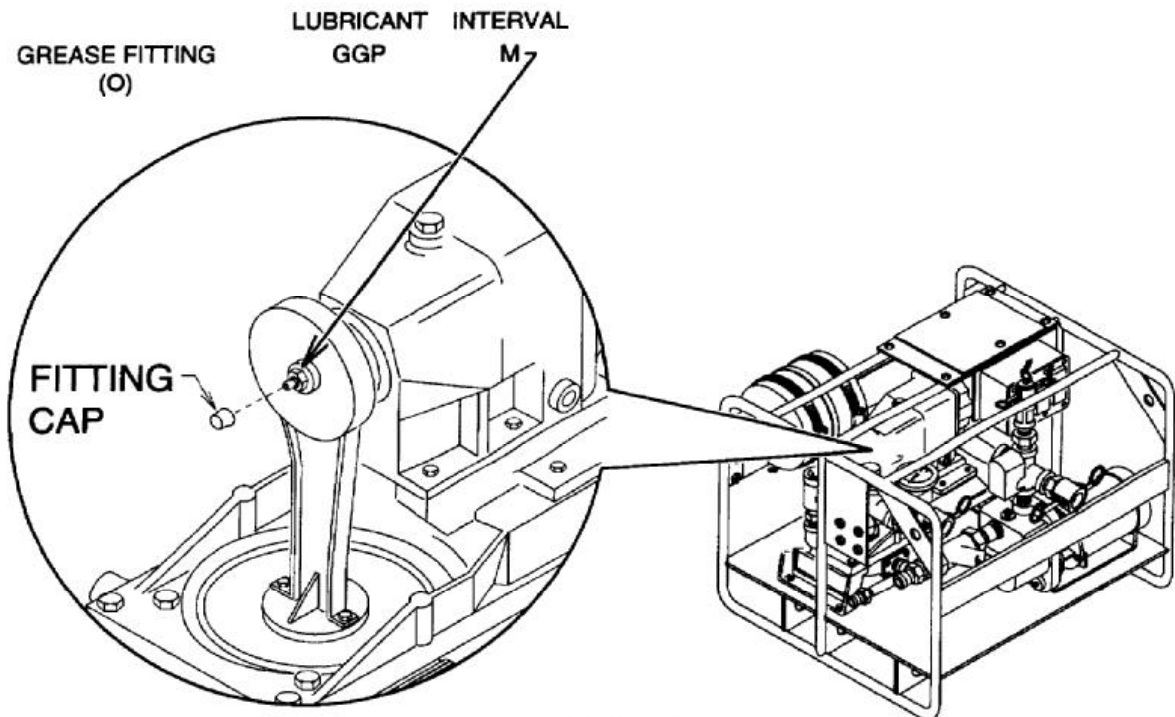

Figure 4-2. Lubrication

SECTION III UNIT TROUBLESHOOTING PROCEDURES

This section cannot list all the possible malfunctions that may occur with the equipment. If a malfunction occurs that is not listed or actions listed do not correct a malfunction, notify your supervisor.

Table 4-2. Unit Maintenance Troubleshooting

MALFUNCTION 1. NO POWER TO PUMP ASSEMBLY.

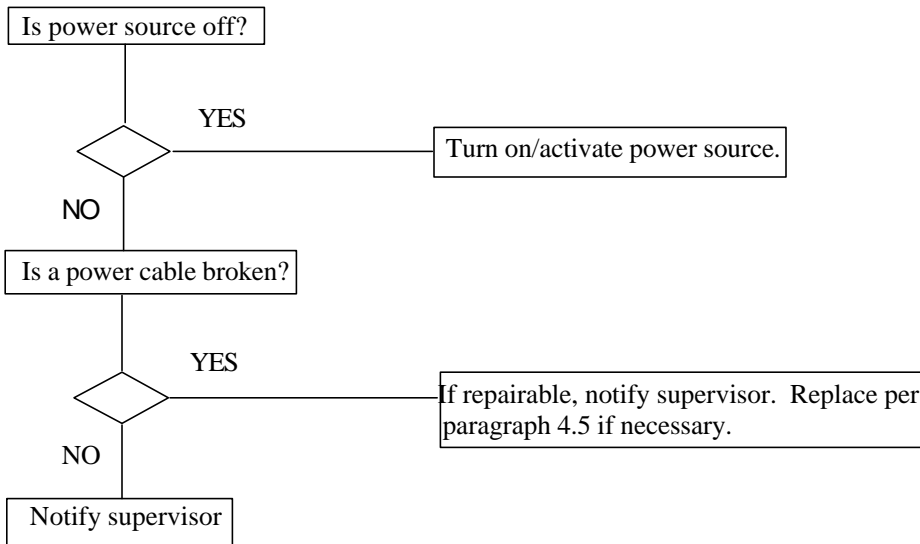

MALFUNCTION 2. NO POWER TO SUPPLY PUMP OR DIAPHRAGM (DRAIN) PUMP.

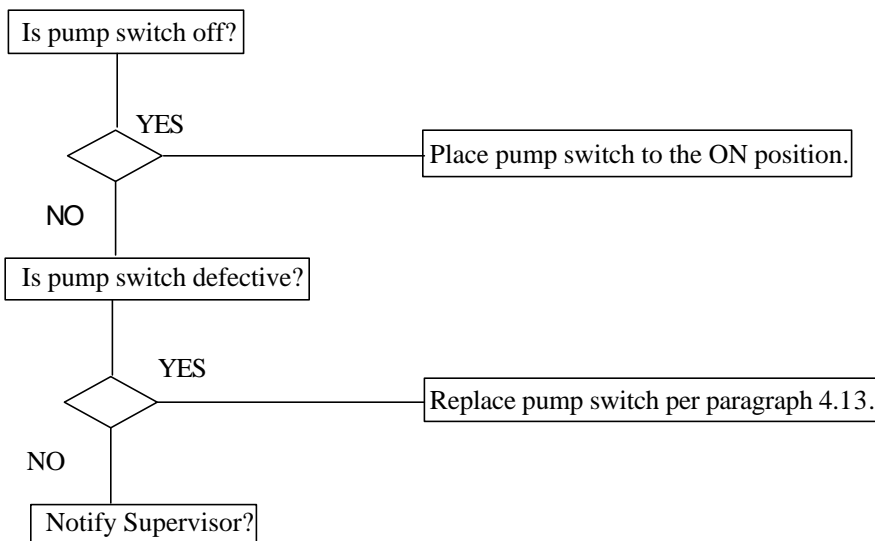

SECTION IV UNIT MAINTENANCE PROCEDURES

4.5. POWER CABLE ASSEMBLIES TESTING AND REPLACEMENT.

This task covers: a. Inspection b. Removal c. Testing d. Installation

INITIAL SETUP

Tools:

Multimeter (Appendix B, Section III, Item 2)

Equipment:

Shower facility shut down, paragraph 2.7.
Input power connector disconnected from power source.

General Safety Instructions:

WARNING

High voltage is used in the portable shower module. Care must be taken to avoid personnel injury or death from energizing circuits.

Refer to figure 4-3.

- a. Inspection. Check power cable assemblies for damage, deterioration, or missing parts. Replace assembly if necessary. Send removed assembly to direct support maintenance for repair.
- b. Removal. Disconnect system power cable assembly (1) from input power cable assembly (2), pump assembly, and any other attached item.
- c. Testing.
 - (1) Using multimeter set to measure continuity, check between each input power cable assembly loose lead (3) and the corresponding contact point (4) on the connector. Replace cable assembly (2) if no continuity is indicated on any one lead.
 - (2) Using multimeter set to measure continuity, check between system power cable assembly plug contact points (5) and the corresponding contact points (6) on each connector. Replace cable assembly (1) if no continuity is indicated on any lead.
- d. Installation.
 - (1) Connect system power cable assembly (1) to pump assembly, any other attached item, and input power cable assembly (2).
 - (2) Connect input power cable assembly (2) to power source if disconnected and start up the shower facility. See paragraph 2.7.

4.5. POWER CABLE ASSEMBLY TESTING AND REPLACEMENT. - CONTINUED

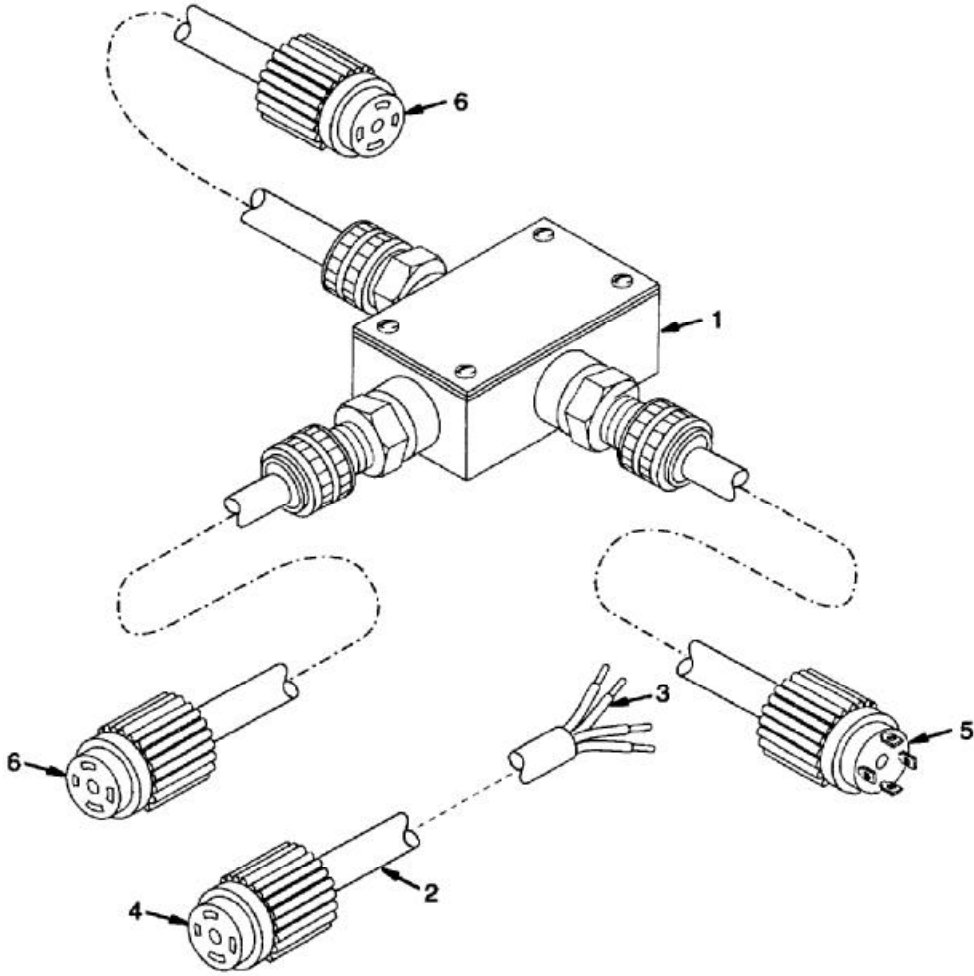

Figure 4-3. Power Cable Assemblies

4.6. PORTBLE SHOWER BASE REPAIR OR REPLACEMENT.

This task covers: a. Inspection b. Removal c. Disassembly d. Assembly e. Installation

INITIAL SETUPTools:

General Mechanics Tool Set (Appendix B, Section III, Item 1).

Equipment:

Shower facility shut down, paragraph 2.7.

Materials/Parts:

Sealing Compound (Appendix E, Item 1)

Refer to figure 4-4.

- a. Inspection. Check for damage, deterioration, or missing parts. Based on the inspection, determine if the shower base can be repaired or if it must be replaced.

NOTE

Remove only if necessary for repair.

- b. Removal. Disassemble shower facility only to the extent necessary for removal of the shower base being repaired/replaced. See paragraph 4.19.

NOTE

Repair is limited to replacement of defective, missing, or damaged components. Disassemble only to the extent necessary to repair the item.

- c. Disassembly.

- (1) Remove four screws (1) and grate (2).
- (2) Remove 30 screws (3), flat washers (4), and two each hook fastener strips (5 and 6).
- (3) Remove 12 screws (7) and four tube liners (8).
- (4) Remove four screws (9) and two tube liners (10).
- (5) Remove ring (11) and chain (12).
- (6) Remove cap (13).
- (7) Remove coupling (14).

4.6. PORTABLE SHOWER BASE REPAIR OR REPLACEMENT. – CONTINUED

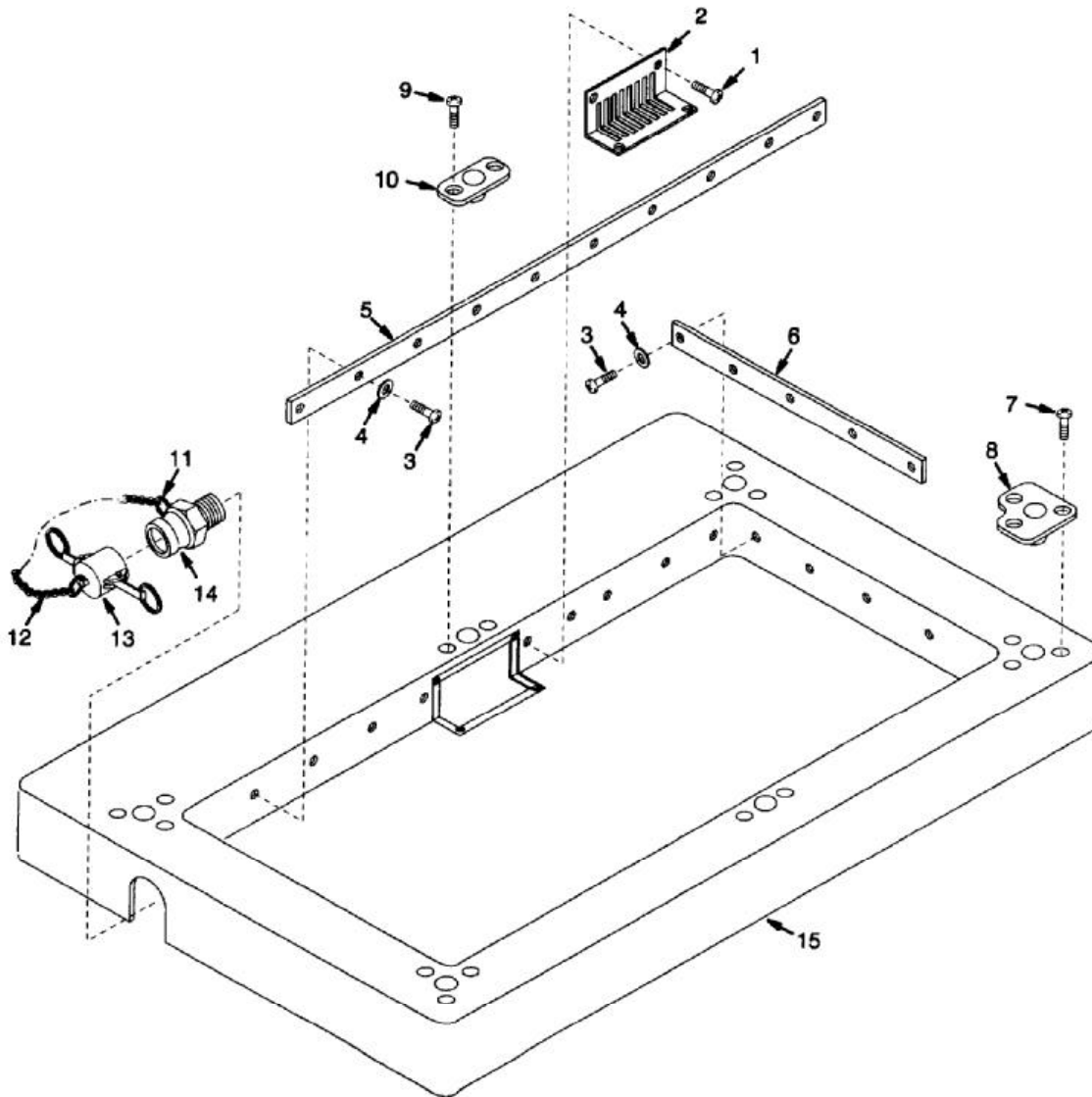

Figure 4-4. Portable Shower Base

d. Assembly.

- (1) Be sure any defective, missing, or damaged components have been replaced.
- (2) Apply sealing compound to threads of coupling (14) and install into shower base (15).
- (3) Install cap (3).
- (4) Install ring (11) and chain (12).
- (5) Install two tube liners (10) and secure using four screws (9).
- (6) Install four tube liners (8) and secure using 12 screws (7).
- (7) Install two each hook fastener strips (5 and 6) and secure using 30 flat washers (4) and screw (3).
- (8) Install grate (2) and secure using four screws (1).

e. Installation.

- (1) Assemble shower facility as necessary. See paragraph 2.6.
- (2) Start up the shower facility. See paragraph 2.7.

4.7. TOP FRAME SUPPLY ASSEMBLY REPAIR OR REPLACEMENT.

This task covers: a. Inspection b. Removal c. Disassembly d. Assembly e. Installation

INITIAL SETUP

Tools:

General Mechanics Tool Set (Appendix B, Section III, Item 1).
Pipe Wrench (Appendix B, section III, Item 2)
Fitted Wrench (Appendix B, Section III, Item 2)

Equipment:

Shower facility not in use.
Shower facility shut down, paragraph 2.7.

Materials/Parts:

Sealing Compound (Appendix E, Item 1)
Self Locking Nuts (8) (Appendix G, Item 1)

Refer to figure 4-5.

- a. Inspection. Check for damage, or missing parts. Based on the inspection, determine if the top frame assembly can be repaired or if it must be replaced.

NOTE

Remove only if necessary for repair.

- b. Removal. Disassemble shower facility only to the extent necessary for removal of the top frame assembly being repaired/replaced. See paragraph 4.19.

NOTE

Repair is limited to replacement of defective, missing, or damaged components. Disassemble only to the extent necessary to repair the item.

If the item is being replaced, do not disassemble it.

- c. Disassembly.

- (1) Remove two screws (1), flat washers (2), and hook and pile fastener strips (3).

WARNING

Shower head manifold assembly will be loose when U-bolts are removed and must be supported to prevent injury to personnel.

- (2) Remove eight self locking nuts (4), flat washers (5), four U-bolts (6), and two pipe brackets (7). Discard Self-locking nuts.

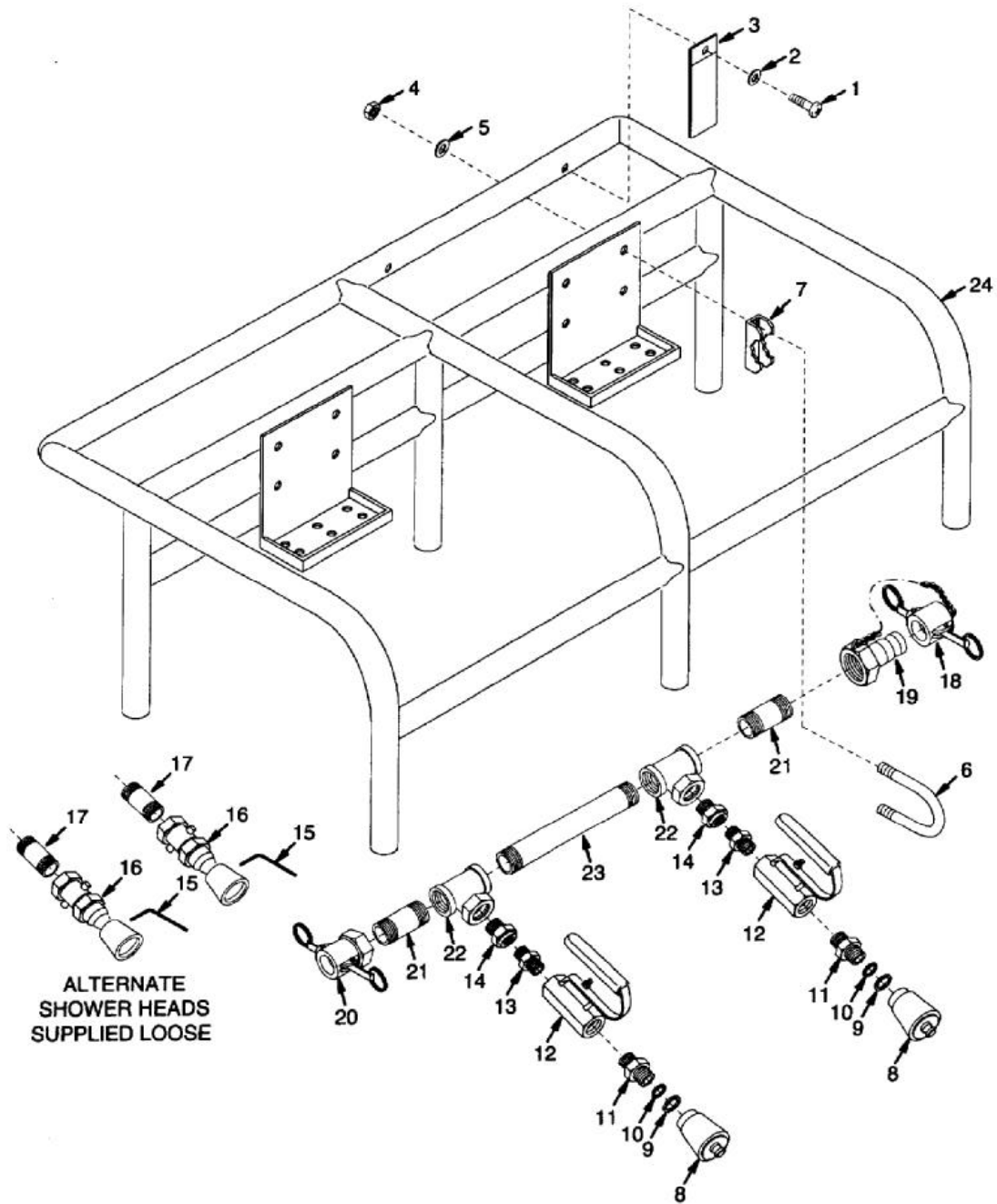

Figure 4-5. Top Frame Assembly

4.7. TOP FRAME ASSEMBLY REPAIR OR REPLACEMENT. – CONTINUED

NOTE

Two different showerheads can be used on the manifold assembly. Use the following procedures as necessary for the showerheads installed.

- (3) Remove two showerheads (8), washers (9), gaskets (10), and adapter (11).
- (4) Remove two valves (12), nipples (13), and bushings (14).
- (5) If alternate showerheads are being used, loose setscrews as necessary using hex wrench (15) then remove two showerheads (16) and nipples (17).
- (6) Remove cap (18) and couplings (19 and 20).
- (7) Remove two nipples (21) and tees (22) from nipple (23).

d. Assembly.

- (1) Be sure any defective, missing, or damaged components have been replaced.
- (2) Apply sealing compound to threaded ends of nipple (23) and install two tees (22). Be sure both tee side fittings are facing the same direction.
- (3) Apply sealing compound to threaded ends of two nipples (21) then install nipples, and couplings (19 and 20 as illustrated).

NOTE

Two different showerheads can be used on the manifold assembly. Use the following procedures as necessary for the showerheads installed.

- (4) Apply sealing compound to threaded end of two bushing (14) and threaded ends of two nipples (13). Install bushings, nipples, and two valves (12) as shown.
- (5) Apply sealing compound to threaded end of two adapters (11) that mates with valve (12) then install two adapters, gaskets (10), washers (9), and showerheads (8).
- (6) If alternate shower heads are being used, apply sealing compound to threaded ends of two nipples (17) then install two nipples and showerheads (16). Adjust showerheads as necessary and secure setscrews using hex wrench (15).
- (7) Place showerhead manifold assembly in place and secure using two pipe brackets (7), four U-bolts (6), eight flat washers (5), and new self-locking nuts (4).
- (8) Install two hook and pile fastener strips (3) and secure using two flat washers (2) and screws (1).

e. Installation.

- (1) Assemble shower facility as necessary. See paragraph 2.6.
- (2) Start up the shower facility. See paragraph 2.7.

4.8. STRAINER ASSEMBLY REPAIR OR REPLACEMENT.

This task covers: a. Inspection b. Removal c. Disassembly d. Assembly e. Installation

INITIAL SETUP

Tools:

General Mechanics Tool Set (Appendix B, Section III, Item 1).
Fitted Wrench (Appendix B, Section III, Item 2)

Materials/Parts:

Sealing Compound (Appendix E, Item 1)
Elastic Stop Nuts (3) (Appendix G, Item 2)

Equipment Conditions:

Shower facility not in use.
Shower facility shut down, paragraph 2.7.

Refer to figure 4-6.

- a. Inspection. Check for damage, or missing parts. Based on the inspection, determine if the strainer assembly can be repaired or if it must be replaced.
- b. Removal. Release coupling (1) and remove strainer assembly.

NOTE

Repair is limited to replacement of defective, missing, or damaged components. Disassemble only to the extent necessary to repair the item.

If the item is being replaced, do not disassemble it.

- c. Disassembly.
 - (1) Remove three elastic stop nuts (2), flat washers (3), bolts (4), flat washers (5), and fiberglass disk (6). Discard elastic stop nuts.
 - (2) Remove coupling (1), nipple (7), bushing (8), strainer (9), and fiberglass disk (10).
- d. Assembly.
 - (1) Be sure any defective, missing, or damaged components have been replaced.
 - (2) Apply sealing compound onto threaded end of bushing (8) and threaded ends of nipple (7). Assemble fiberglass disk (10), strainer (9), bushing, nipple, and coupling (1).
 - (3) Assemble fiberglass disk (6), strainer (9), and fiberglass disk (10) using three flat washers (5), bolts (4), flat washers (3), and new elastic stop nuts (2).
- e. Installation.
 - (1) Install strainer assembly and secure coupling (1).
 - (2) Start up the shower facility. See paragraph 2.7.

4.8. STRAINER ASSEMBLY REPAIR OR REPLACEMENT. – CONTINUED

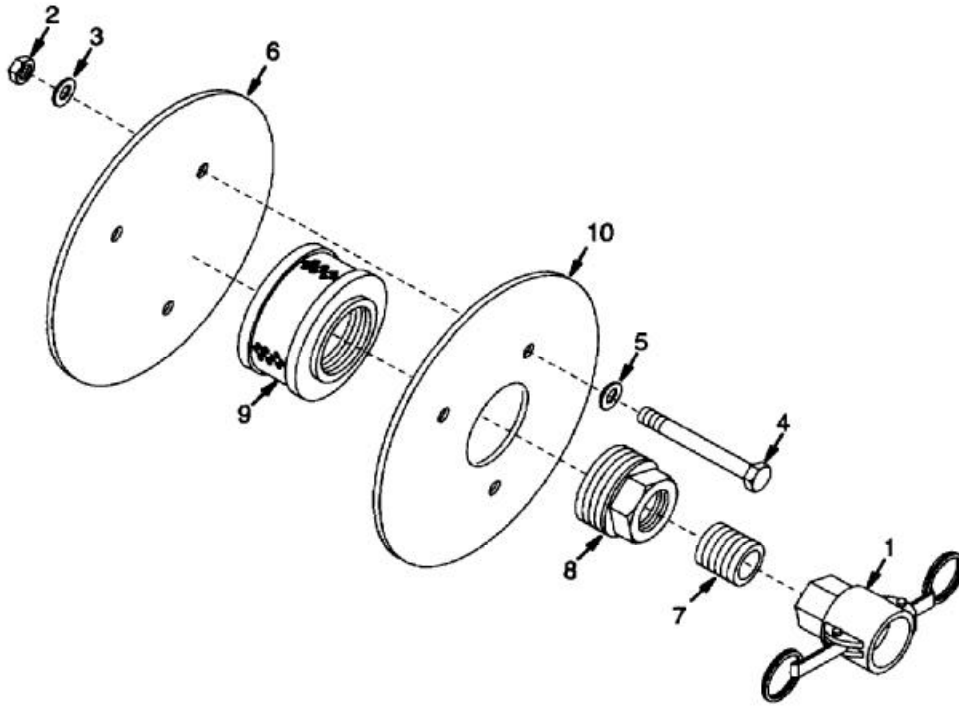

Figure 4-6. Strainer Assembly

4.9. SPRING CHECK VALVE ASSEMBLY REPAIR OR REPLACEMENT.

This task covers: a. Inspection b. Removal c. Disassembly d. Assembly e. Installation

INITIAL SETUP

Tools:

Pipe Wrench (Appendix B, Section III, Item 2), 2 each

Equipment Conditions:

Shower facility not in use.
Shower facility shut down, paragraph 2.7.

Materials/Parts:

Sealing Compound (Appendix E, Item 1)

Refer to figure 4-7.

- a. Inspection. Check for damage or missing parts. Based on the inspection, determine if the spring check valve assembly can be repaired or it must be replaced.
- b. Removal.
 - (1) Remove strainer assembly. See paragraph 4.8.
 - (2) Release coupling (1) and remove spring check valve assembly.

NOTE

Repair is limited to replacement of defective, missing, or damaged components.
Disassemble only to the extent necessary to repair the item.

If the item is being replaced, do not disassemble it.

- c. Disassembly. Remove couplings (1 and 2) from spring check valve (3).
- d. Assembly.
 - (1) Be sure any defective, missing, or damaged components have been replaced.
 - (2) Apply sealing compound to threaded ends of couplings (1 and 2) and install coupling onto spring check valve (3). Note flow direction when installing coupling.
- e. Installation.
 - (1) Install spring check valve assembly and secure coupling (1).
 - (2) Install strainer assembly. See paragraph 4.8.
 - (3) Start up shower facility. See paragraph 2.7.

4.9. SPRING CHECK VALVE ASSEMBLY REPAIR OR REPLACEMENT. – CONTINUED

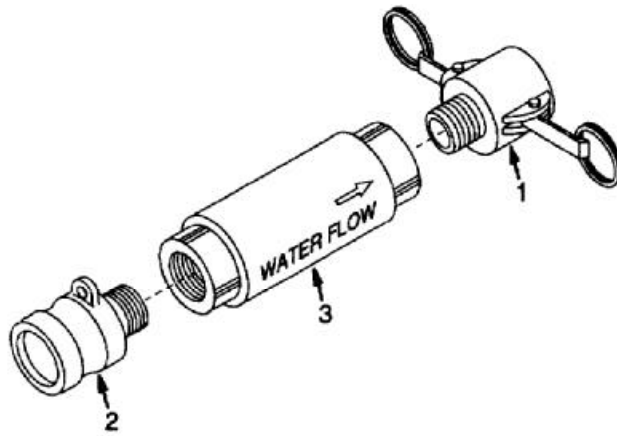

Figure 4-7. Spring Check Valve Assembly

4.10. REGULATOR VALVE ASSEMBLY REPAIR OR REPLACEMENT.

This task covers: a. Inspection b. Removal c. Disassembly d. Assembly e. Installation

INITIAL SETUPTools:

General Mechanics Tool Set (Appendix B, Section III, Item 1)
 Pipe Wrench (Appendix B, Section III, Item 2)
 Fitted Wrench (Appendix B, Section III, Item 2)

Equipment Conditions:

Shower facility not in use.
 Shower facility shut down, paragraph 2.7.

Materials/Parts:

Sealing Compound (Appendix E, Item 1)
 1, Appendix E

Refer to figure 4-8.

- a. Inspection. Check for damage or missing parts. Based on the inspection, determine if the regulator valve assembly can be repaired or it must be replaced.

NOTE

Replacement consists only of removal and installation of a defective or damaged item.

If the item is repairable, remove only if it cannot be disassembled to extent necessary while installed.

- b. Removal. Release couplings and remove regulator valve assembly.

NOTE

Repair is limited to replacement of defective, missing, or damaged components. Disassemble only to the extent necessary to repair the item.

If the item is being replaced, do not disassemble it.

- c. Disassembly.

- (1) If necessary, release reducer (1) and cap (2) couplings then remove plug (3), gasket (4), cap, and gasket (5).
- (2) Release reducer (6) coupling then remove reducer and gasket (7).
- (3) Release coupling (8) then remove reducer (1) and gasket (9).
- (4) Remove couplings (8 and 10) from regulator valve (11).

4.10. REGULATOR VALVE ASSEMBLY REPAIR OR REPLACEMENT. - CONTINUED

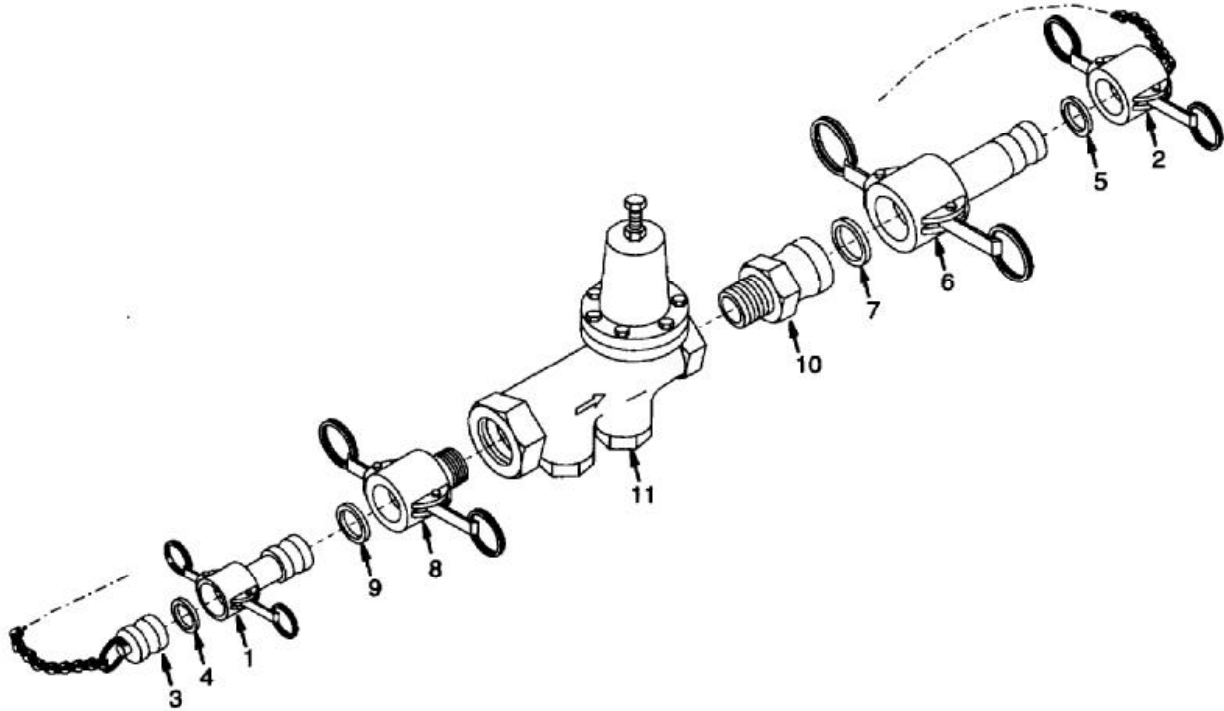

Figure 4-8. Regulator Valve Assembly

d. Assembly.

- (1) Be sure any defective, missing, or damaged components have been replaced.
- (2) Apply sealing compound to threaded ends of couplings (8 and 10) then install couplings onto regulator valve (11). Note flow direction when installing couplings.
- (3) Install gasket (9) and reducer (1) then secure coupling (8).
- (4) Install gasket (7) and reducer (6) then secure reducer coupling.
- (5) Install gasket (5) into cap (2) and gasket (4) into reducer (1) then if necessary install plug (3) and cap then secure cap and reducer couplings.

e. Installation.

- (1) Install regulator valve assembly and secure and couplings.
- (2) Start up the shower facility. See paragraph 2.7.

4.11. SHOWER FACILITY INTERCONNECTON HOSE ASSEMBLIES REPAIR OR REPLACEMENT.

This task covers: a. Inspection b. Removal c. Disassembly d. Assembly e. Installation

INITIAL SETUP

Tools:

General Mechanics Tool Set (Appendix B, Section III, Item 1)

Equipment Conditions:

Shower facility not in use.
Shower facility shut down, paragraph 2.7.

Refer to figure 4-9.

- a. Inspection. Check for damage, deterioration, or missing parts. Based on the inspection, determine if the hose assembly can be repaired or if it must be replaced.
- b. Removal. Release couplings and remove hose assembly.

NOTE

Repair is limited to replacement of defective, missing, or damaged components. Disassemble only to the extent necessary to repair the item.

If the item is being replaced, do not disassemble it.

- c. Disassembly.
 - (1) Loosen two clamps (1) the remove coupling (2) and clamps.
 - (2) Loosen two clamps (3) the remove coupling (4) and clamps.
- d. Assembly.
 - (1) Be sure any defective, missing, or damaged components have been replaced.
 - (2) Slide two clamps (3) over hose (5) end and install coupling (4). Be sure clamps are around coupling and tighten clamps.
 - (3) Slide two clamps (1) over hose (5) end and install coupling (2). Be sure clamps are around coupling and tighten clamps.
- e. Installation.
 - (1) Install hose assembly and secure couplings.
 - (2) Start up the shower facility. See paragraph 2.7.

4.11. SHOWER FACILITY INTERCONNECTON HOSE ASSEMBLIES REPAIR OR REPLACEMENT. -
CONTENUED

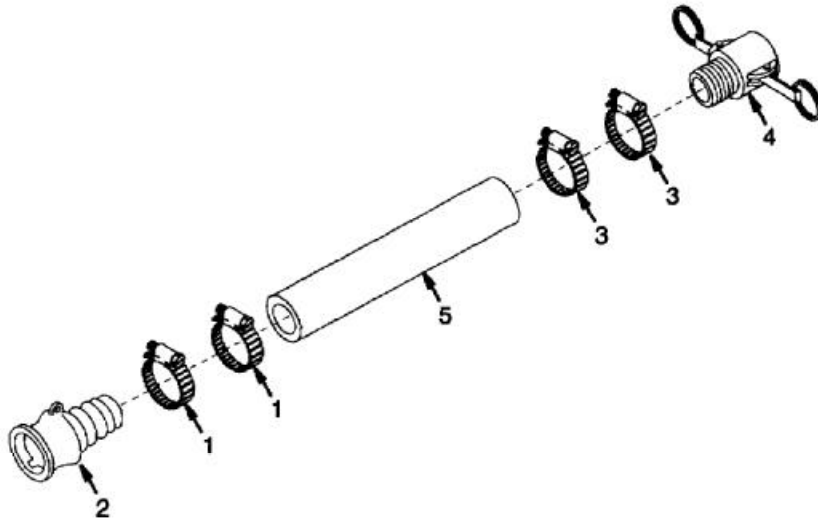

Figure 4-9. Typical Shower Facility Interconnection Hose Assembly

4.12. SUPPLY PUMP COLD LINE HOSE ASSEMBLIES REPAIR OR REPLACEMENT.

This task covers: a. Inspection b. Disassembly/ Removal c. Assembly/Installation

INITIAL SETUP

Tools:

General Mechanics Tool Set (Appendix B, Section III, Item 1)

Equipment Conditions:

Shower facility not in use.
Shower facility shut down, paragraph 2.7.

Materials/Parts:

Sealing Compound (Appendix E, Item 1)

Refer to figure 4-9.

a. Inspection. Check for damage, deterioration, or missing parts. Based on the inspection, determine to what extent the hose assembly must be disassembled to be repaired or replaced.

NOTE

Repair is limited to replacement of defective, missing, or damaged components. Disassemble only to the extent necessary to repair the item.

b. Disassembly/Removal.

- (1) Loosen two clamps (1) then pull hose (2) end off coupling (3) and remove clamps.
- (2) Loosen two clamps (4) then pull hose (2) end off coupling (5) and remove clamps.
- (3) Remove couplings (3 and 5) from pump assembly.

c. Assembly/Installation.

- (1) Be sure any defective, missing, or damaged components have been replaced.

NOTE

Supply pump cold line hose assembly couplings are issued as a set.

- (2) Apply sealing compound to threaded end of coupling (3) and threaded end of connector (5) mating connector. Install couplings into pump assembly.
- (3) Slide two clamps (4) over hose (2) end and install hose onto coupling (5). Be sure clamps are around coupling and tighten clamps.
- (4) Slide two clamps (1) over hose (2) end and install hose onto coupling (3). Be sure clamps are around coupling and tighten clamps.
- (5) Start up the shower facility. See paragraph 2..7.

4.12. SUPPLY PUMP COLD LINE HOSE ASSEMBLIES REPAIR OR REPLACEMENT. - CONTINUED

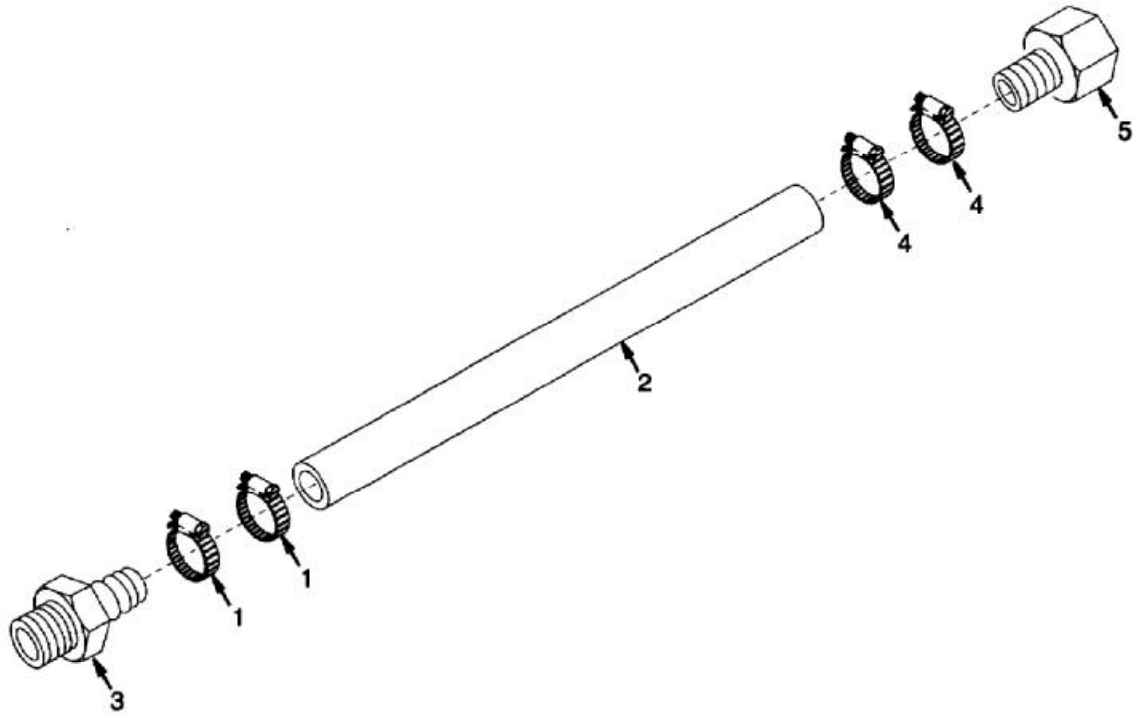

Figure 4-10. Typical Supply Pump Cold Line Hose Assembly

4.13. SWITCH BOX ASSEMBLY TESTING, REPAIR, OR REPLACEMENT.

This task covers: a. Inspection b. Testing c. Removal d. Disassembly e. Assembly

INITIAL SETUP

Tools:

General Mechanics Tool Set (Appendix B, Section III, Item 1)
Multimeter (Appendix B, Section III, Item 2)

Materials/Parts:

Lock Washers (4) (Appendix G, Item 3)
Lock Washers (3) (Appendix G, Item 4)
Lock Washers (3) (Appendix G, Item 53)
Sealing Compound (Appendix E, Item 1)
Adhesive (Appendix E, Item 1)

Equipment Conditions:

Shower facility not in use.
Shower facility shut down and power disconnected, paragraph 2.7.

General Safety Instructions:**WARNING**

High voltage is used on the portable shower module. Care must be taken to avoid personal injury or death from energizing circuits.

Refer to figure 4-11.

a. Inspection.

- (1) Be sure power has been disconnected at the source then disconnect input power cable from switch box.
- (2) Remove 10 screws (1) and carefully pull switch box cover (2) out as far as wire leads will allow.
- (3) Check for damage, deterioration, or missing parts. Based on the inspection, determine if the switch box assembly can be repaired or if it must be replaced.

b. Testing.

- (1) Using multimeter set to measure continuity, check each switch (3). Place both switches on the OFF position and check continuity between matching color leads on top and bottom of each switch. Replace switch if continuity was indicated.
- (2) Place both switches in the ON position and check continuity between matching color leads on top and bottom of each switch. Replace switch if no continuity was indicated.
- (3) Using multimeter set to measure continuity, check between ends of wire leads at terminal connections. Remove pressure switch and motor covers as necessary and use electrical schematic (Figure 1-3) for test points. Replace any wire leads that do not indicate continuity

4.13. SWITCH BOX ASSEMBLY TESTING, REPAIR, OR REPLACEMENT. - CONTINUED

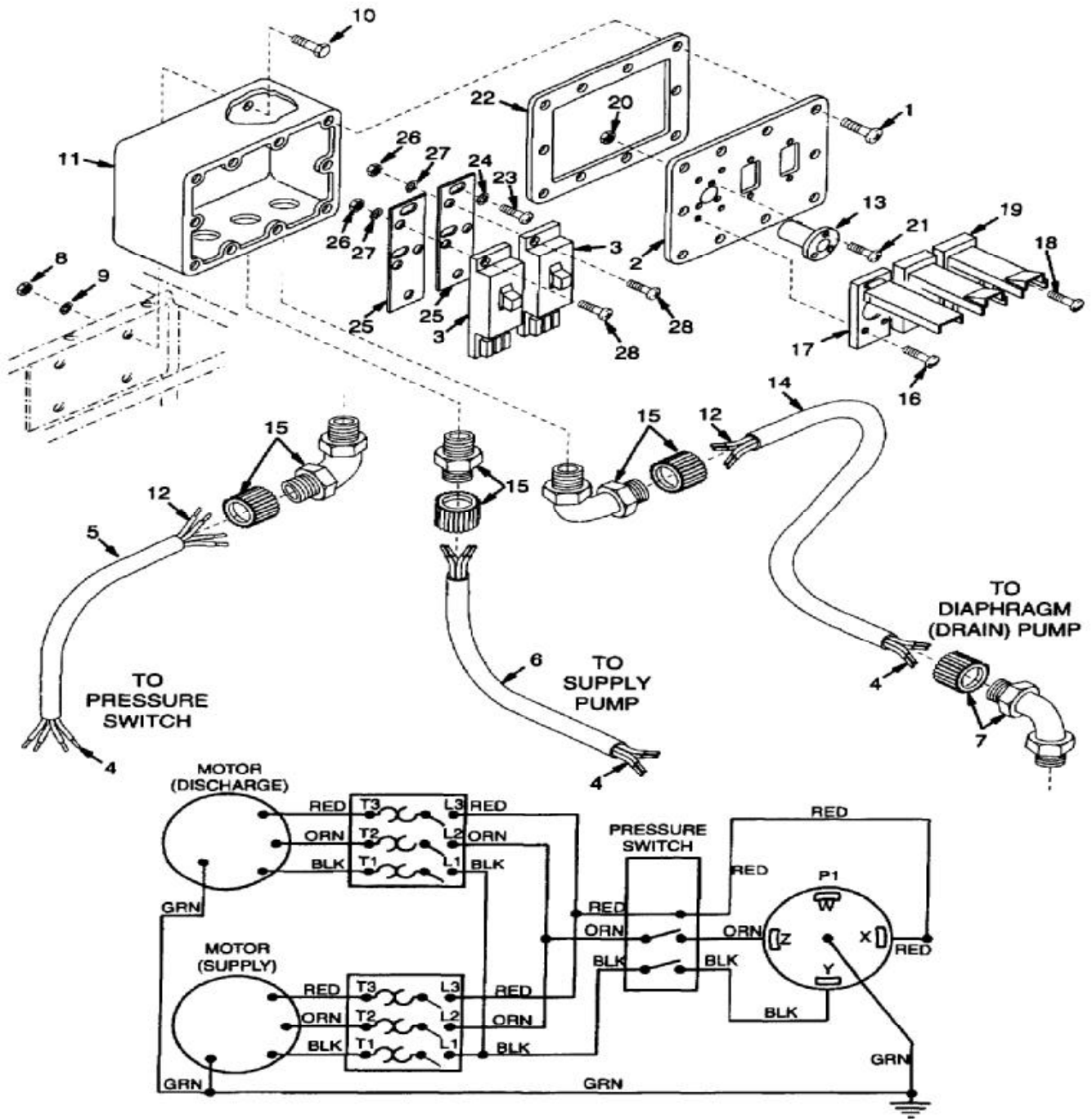

Figure 4-11. Switch Box Assembly

NOTE

Remove only if necessary for repair.

c. Removal.

- (1) If switch box cover (2) is not already loose, remove 10 screws (1) and carefully pull switch box cover out as far as wire leads will allow.
- (2) Tag and disconnect wire leads (4) from pressure switch, supply pump, and diaphragm (drain) pump. Remove covers as necessary to access lead terminals.
- (3) Remove conduit (5) from pressure switch conduit connector, conduit (6) from supply pump conduit connector, and conduit connector (7) from diaphragm (drain) pump.
- (4) Remove four nuts (8), lock washers (9), bolts (10), and switch box assembly (11). Discard lock washers.

NOTE

Repair is limited to replacement of defective, missing, or damaged components. Disassemble only to the extent necessary to repair the item. If the item is being replaced, do not disassemble it.

d. Disassembly.

- (1) If switch box cover (2) is not already loose, remove 10 screws (1) and carefully pull switch box cover out as far as wire leads will allow.
- (2) Tag and disconnect wire leads (12) from each other as well as switches (3) and receptacle (13).
- (3) Remove conduit connector (7) from conduit (14).
- (4) Remove conduit (5, 6, and 14) with wire leads inside then remove wire leads from conduit.
- (5) Remove three conduit connectors (15).
- (6) Remove four screws (16) and cover (17).
- (7) Remove four screws (18) and two covers (19).
- (8) Remove three nuts (20), screws (21), and receptacles (13).
- (9) If gasket (22) needs to be replaced, remove it by carefully pulling and scraping it off switch box cover (2).
- (10) Remove six screws (23), lock washers (24), screws (25), and two switches (3). Discard lock washers.
- (11) Remove six nuts (26), lock washers (27), screws (28), and two switches (3). Discard lock washers.

4.13. SWITCH BOX ASSEMBLY TESTING, REPAIR, OR REPLACEMENT. - CONTINUED

e. Assembly.

- (1) Be sure any defective, missing, or damaged components have been replaced.
- (2) Apply sealing compound to the threads of six screws (28) then assemble two switches (3) and plates (25) using the six screws, new lock washers (27) and nuts (26) to secure them.
- (3) Apply sealing compound to the threads of six screws (23) then install two plates (25), with switches (3) attached, using the six screws and new lock washers (24) to secure them.
- (4) If gasket (22) was removed, apply adhesive to mating surfaces of new gasket and switch box cover (2). Allow adhesive to dry until it is tacky but will not stick to fingers then assemble by pressing firmly together. Make sure gasket is secure all round cover.
- (5) Apply sealing compound to the threads of three screws (21) then install receptacle (13) and secure using the three screws and nuts (20).
- (6) Apply sealing compound to the threads of four screws (18) then install two covers (19) and secure using the four screws.
- (7) Apply sealing compound to the threads of four screws (16) then install cover (17) and secure using four screws.
- (8) Install three conduit connectors (15) as illustrated.
- (9) Install wire leads into conduit (5, 6, and 14) using tags and electrical schematic figure 1-3. Remove tags.
- (10) Install conduit (5, 6, and 14) into conduit connectors (15) as illustrated using electrical schematic (Figure 1-3).
- (11) Install conduit connector (7) onto conduit (14).
- (12) Connect wire leads (12) to each other as well as switches (3) and receptacle (13) using tags and electrical schematic (Figure 1-3). Remove tags.

f. Installation.

- (1) If switch box cover (2) is not already loose, remove 10 screws (1) and carefully pull switch box cover out as far as wire leads will allow.
- (2) Apply sealing compound to the threads of four bolts (10) then install switch box assembly (11) and secure using the four bolts, new lock washers (9), and nuts (8).
- (3) Install conduit (5) into pressure switch conduit connector, conduit (6) into supply pump conduit connector, and conduit connector (7) onto diaphragm (drain) pump.
- (4) Connect wire leads (4) to pressure switch, supply pump, and diaphragm (drain) pump using tags and electrical schematic 1-3. Remove tags and install covers as necessary.
- (5) Apply sealing compound to the threads of 10 screws (1) then position switch box cover (2) in place and secure using the 10 screws.
- (6) Start up the shower facility. See paragraph 2.7.

4.14. SUPPLY PUMP ASSEMBLY REPLACEMENT.

This task covers: a. Removal b. Installation

INITIAL SETUP

Tools:

General Mechanics Tool Set (Appendix B, Section III, Item 1)
 Pipe Wrench (Appendix B, Section III, Item 2)
 Fitted Wrench (Appendix B, Section III, Item 2)

Materials/Parts:

Sealing Compound (Appendix E, Item 1)
 Marker Tags (Appendix E, Item 5)
 Self Locking Nuts (4) (Appendix G, Item 5)
 Sealing Compound (Appendix G, Item 5)

Equipment Conditions:

Shower facility not in use.
 Shower facility shut down and power disconnected, paragraph 2.7.

General Safety Instructions:

WARNING

High voltage is used on the portable shower module. Care must be taken to avoid personal injury or death from energizing circuits.

Refer to figure 4-12.

a. Removal.

- (1) Release coupling (1) and disconnect mating hose end coupling.
- (2) Release mating hose end coupling connected to coupling (2) and disconnect.
- (3) Loosen nut (3) and remove cover (4). Tag and disconnect wire leads from pressure switch (5).
- (4) Remove four screws (6), cover (7), and gasket (8). Tag and disconnect wire leads from supply pump (9).
- (5) Remove conduit, with wire leads inside, from two conduit connectors (10) then remove conduit connectors.
- (6) Release coupling (11) and remove plug (12).
- (7) Remove clod line hose assembly from cross fitting (13). See paragraph 4.12.
- (8) Remove coupling (2), bushing (14), strainer (15), and nipple (16).
- (9) Remove coupling (11), coupling (17), nipple (18), and bushing (19).
- (10) Remove coupling (1).
- (11) Remove pressure switch (5) and nipple (20).
- (12) Remove cross fitting (13) and nipple (21).
- (13) Remove four self-locking nuts (22), flat washers (23), bolts (24), flat washers (25), and supply pump (9). Discard self-locking nuts.

4.14. SUPPLY PUMP ASSEMBLY REPLACEMENT. - CONTINUED

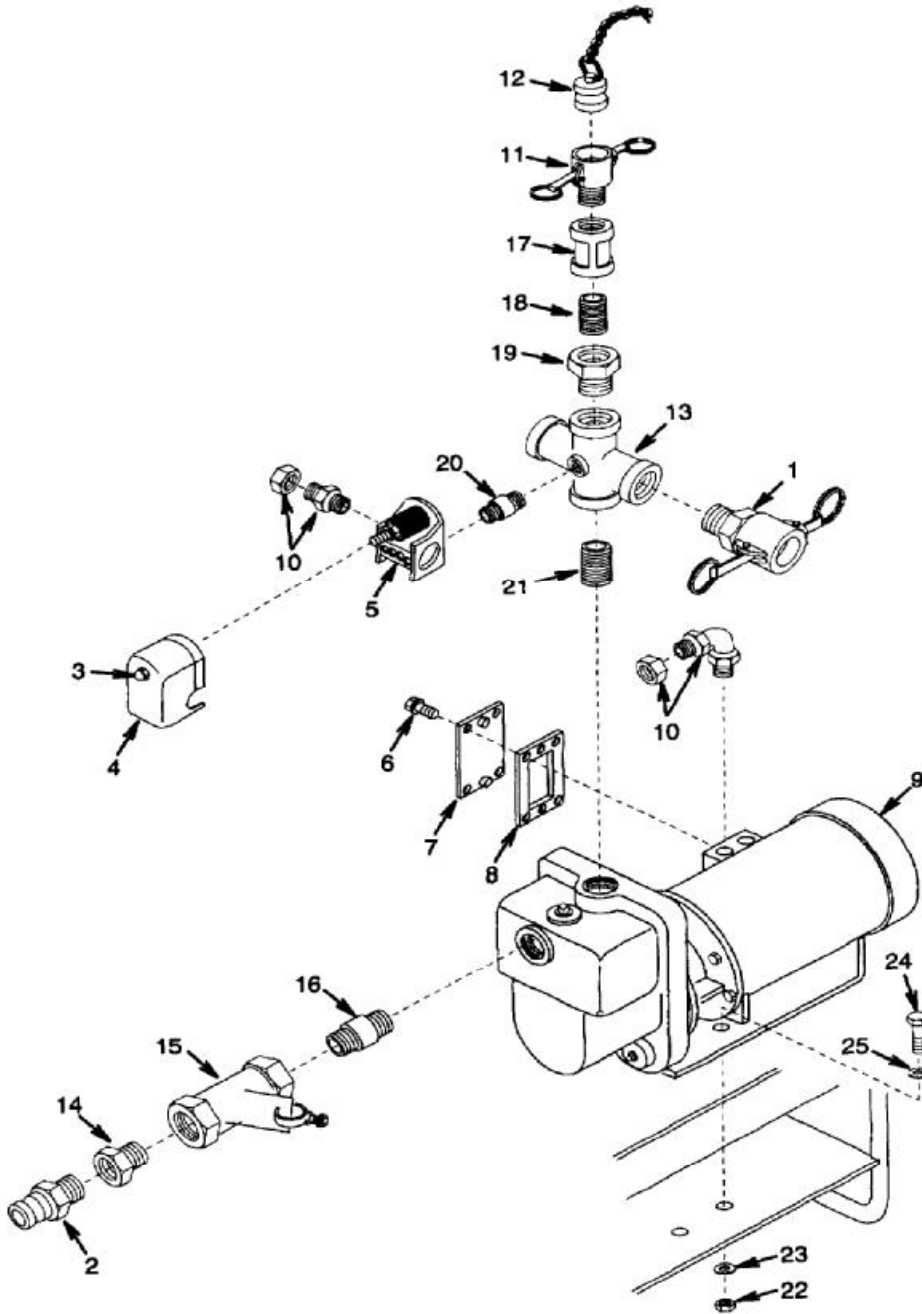

Figure 4-12. Supply Pump Assembly

- (14) Replace any defective, missing, or damaged components.
- (15) Send removed supply pump (9) to direct support maintenance for repair.

d. Installation.

- (1) Be sure any defective, missing, or damaged components have been replaced.
- (2) Install supply pump (9) and align mounting holes. Secure using four flat washers (25), bolts (24), flat washers (23), and new self-locking nuts (22).
- (3) Apply sealing compound to threaded ends of nipple (21) then install nipple and cross fitting (13). Be sure cross fitting is installed as illustrated.
- (4) Apply sealing compound to threaded ends of nipple (20) then install nipple and pressure switch (5). Be sure pressure switch is upright when installing.
- (5) Apply sealing compound to threaded end of coupling (1) then install coupling.
- (6) Apply sealing compound to threaded end (s) of bushing (19), nipples (18), and coupling (11) then install bushing, nipple, coupling (17), and coupling (11).
- (7) Apply sealing compound to threaded end (s) of coupling (2), bushing (14), and nipple (16) then install nipple, strainer (15), bushing and coupling.
- (8) Install cold line hose assembly onto cross fitting (13). See paragraph 4.12.
- (9) Install plug (12) and secure coupling (11).
- (10) Install two conduit connectors (10) then install conduit, with wire leads inside, into conduit connectors.
- (11) Connect wire leads to pressure switch (5) and supply pump (9) using tags and electrical schematic figure 4-11. Remove tags.
- (12) Install gasket (8), cover (7), and four screws (6).
- (13) Install cover (4), and secure nut (3).
- (14) Connect mating hose end coupling to coupling (2) and secure coupling.
- (15) Connect mating hose end coupling to coupling (1) and secure coupling.
- (16) Start up shower facility. See paragraph 2.7.

4.15 REGULATOR ASSEMBLY (TEMPREATURE) REPAIR OR REPLACEMENT.

This task covers: a. Inspection b. Removal c. Disassembly d. Assembly e. Installation

INITIAL SETUP

Tools:

General Mechanics Tool Set (Appendix B, Section III, Item 1)
Pipe Wrench (Appendix B, Section III, Item 2)
Fitted Wrench (Appendix B, Section III, Item 2)

Equipment Conditions:

Shower facility not in use.
Shower facility shut down, paragraph 2.7.

Materials/Parts:

Sealing Compound (Appendix E, Item 1)
Lock Washers (4) (Appendix G, Item 7)
Self-Locking Nuts (4) (Appendix G, Item 7)

Refer to figure 4-13.

- a. Inspection. Check for damaged or missing parts. Based on the inspection, determine if the regulator assembly can be repaired or replaced.

NOTE

Remove only if necessary for repair.

- b. Removal.

- (1) Release coupling (1) and disconnect mating hose end coupling.
- (2) Release mating hose end coupling connected to coupling (2) and disconnect.
- (3) Remove cold line hose assembly from bushing (3). See paragraph 4.12.
- (4) Remove four self locking nuts (4), lock washers (5), flat washers (6), two U-bolts (7), bracket (8), and regulator (9) assembly. Discard self-locking nuts and lock washers.

NOTE

Repair as limited to replacement of defective, missing, or damaged components. Disassemble only to the extent necessary to repair the item.

- c. Disassembly.

- (1) Remove bushing (3), nipple (10), and elbow (11).
- (2) Remove coupling (1), elbow (12), and nipple (13).

- (3) Remove temperature gage (14) and bushing (15).
- (4) Remove coupling (2), tee (16), bushing (17), and nipple (18).

d. Assembly.

- (1) Be sure any defective, missing, or damaged components have been replaced.
- (2) Apply sealing compound to threaded end (s) of nipple (18), bushing (17), and coupling (2) then install nipple, bushing, tee (16), and coupling (2). Be sure tee is installed as illustrated with open fitting end facing up.
- (3) Apply sealing compound to threaded end of bushing (15) and temperature gage (14) then install bushing and temperature gage.

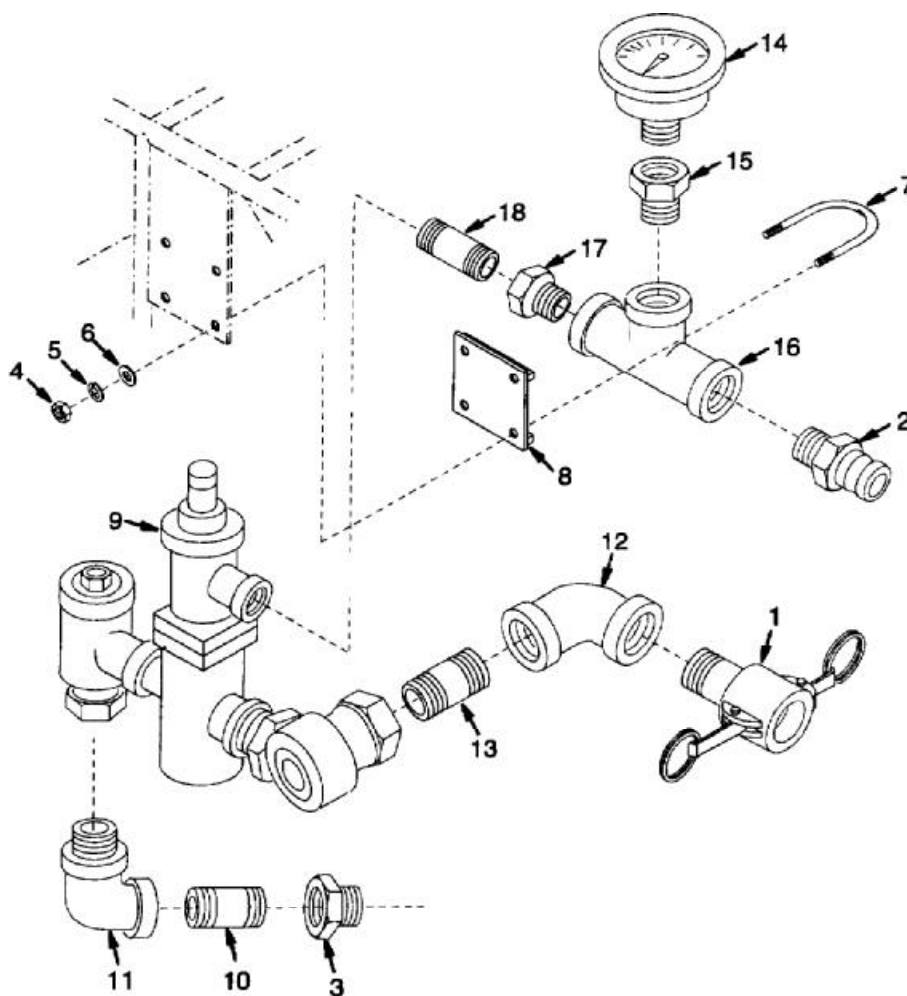

Figure 4-13. Regulator Assembly

4.14. REGULATOR ASSEMBLY (TEMPREATURE) REPAIR OR REPLACEMENT. – CONTINUED

(4) Apply sealing compound to threaded end (s) of nipple (13) and coupling (1) then install nipple, elbow (12), and coupling. Be sure elbow is installed as illustrated.

(5) Apply sealing compound to threaded end (s) of elbow (11), nipple (10), and bushing (3) then install elbow, nipple, and bushing. Be sure elbow is installed as illustrated.

e. Installation.

(1) Install bracket (8) and regulator (9) assembly the secure using two U-bolts (7), four flat washers (6), new locking washers (5), and new self-locking nuts (4). Be sure regulator assembly is installed as illustrated.

(2) Install cold line assembly onto bushing (3). See paragraph 4.12.

(3) Connect mating hose end coupling to coupling (2) and secure coupling.

(4) Connect mating hose end coupling to coupling (1) and secure coupling.

(5) Start up the shower facility. See paragraph 2.7.

4.16. DIAPHRAGM (DRAIN) PUMP ASSEMBLY REPLACEMENT.

This task covers: a. Removal b. Installation

INITIAL SETUP

Tools:

General Mechanics Tool Set (Appendix B, Section III, Item 1)
 Pipe Wrench (Appendix B, Section III, Item 2)
 Fitted Wrench (Appendix B, Section III, Item 2)

Materials/Parts:

Sealing Compound (Appendix E, Item 1)
 Self Locking Nuts (4) (Appendix G, Item 6)
 Tags (Appendix E, Item 5)

Equipment Conditions:

Shower facility not in use.
 Shower facility shut down and power disconnected, paragraph 2.7.

General Safety Instructions:

WARNING

High voltage is used in the portable shower module. Care must be taken to avoid personal injury of death from energized circuits.

Refer to figure 4-14.

a. Removal.

- (1) Release coupling (1) and disconnect mating hose end coupling.
- (2) Release mating hose end coupling connected to coupling (2) and disconnect.
- (3) Remove four screws (3), cover (4), and gasket (5). Tag and disconnect wire leads from diaphragm (drain) pump (6).
- (4) Remove conduit, with wire leads inside, from conduit connector (7) then remove conduit connector.
- (5) Remove coupling (8), nipple (9), and elbow (10).
- (6) Remove coupling (1).
- (7) Remove four self locking nuts (11), flat washers (12), bolts (13), flat washers (14), and diaphragm (drain) pump (6). Discard self-locking nuts.
- (8) Replace any defective, missing, or damaged components.
- (9) Send removed diaphragm (drain) pump (6) to direct support maintenance for repair.

4.16. DIAPHRAGM (DRAIN) PUMP ASSEMBLY REPLACEMENT. - CONTINUED

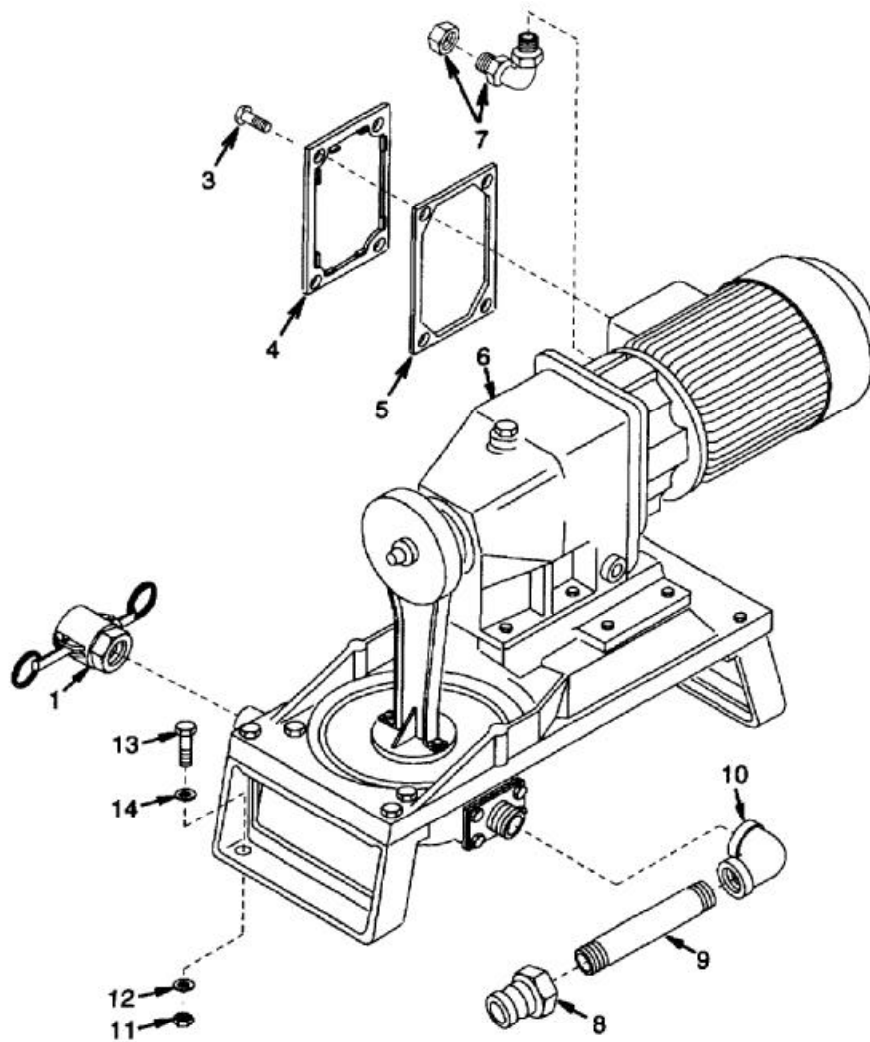

Figure 4-14. Diaphragm (Drain) Pump Assembly

b. Installation.

- (1) Be sure any defective, missing, or damaged components have been replaced.
- (2) Install diaphragm (drain) pump (6) and align mounting holes. Secure using four flat washers (14), bolts (13), flat washers (12), and new self-locking nuts (11).
- (3) Apply sealing compound to threaded ends of nipple (9) and both diaphragm (drain) pump (6) fittings then install elbow (10), nipple (9), and coupling (8).
- (4) Be sure diaphragm (drain) pump (3) threaded fitting has sealing compound applied then install coupling (1).

- (5) Install conduit connector (7) then install conduit, with wire leads inside, into conduit connector.
- (6) Connect wire leads to diaphragm (drain) pump (6) using tags and electrical schematic figure 4-11. Remove tags.
- (7) Install gasket (5), cover (4), and four screws (3).
- (8) Connect mating hose end coupling to coupling (2) and secure coupling.
- (9) Connect mating hose to coupling to coupling (1) and secure coupling.
- (10) Start up the showers facility. See paragraph 2.7.

4.17. DIAPHRAGM TANK & FITTINGS REPAIR OR REPLACEMENT.

This task covers: a. Installation b. Removal c. Disassembly d. Assembly e. Installation

INITIAL SETUP

Tools:

General Mechanics Tool Set (Appendix B, Section III, Item 1)
Pipe Wrench (Appendix B, Section III, Item 2)

Equipment Conditions:

Shower facility not in use.
Shower facility shut down, paragraph 2.7.

Materials/Parts:

Lock Washers (2) (Appendix G, Item 3)
Lock Washers (4) (Appendix G, Item 9)
Sealing Compound (Appendix E, Item 1)

Refer to figure 4-15.

- a. Inspection. Check for damage or missing parts. Based on the inspection, determine if the diaphragm tank and fittings can be repaired or if they must be replaced.

NOTE

Remove only if necessary for repairs.

- b. Removal.

- (1) Remove cold line hose assembly from bushing (1) and elbow (2). See paragraph 4.12.
- (2) Disconnect cold line hose assembly end from tee (3). See paragraph 4.12.
- (3) Remove elbow (4) with bushing (1) attached.
- (4) Remove two clamps (5) and diaphragm tank (6).
- (5) Remove bushing (7) with nipple (8), tee (3), and elbow (2) attached.

NOTE

Repair is limited to replacement of defective, missing or damaged components. Disassemble only to the extent necessary to repair the item.

- c. Disassembly.

- (1) Disassemble elbow (4) and bushing (1).
- (2) Disassemble elbow (2), tee (3), nipple (8), and bushing (7).

NOTE

The following procedure applies to both brackets. The quantities listed in the procedure are for one bracket only.

- (3) Remove nut (9), lock washer (10), bolt (11), and bracket (12). Discard lock washer.
- (4) Remove four nuts (13), lock washers (14), bolt (15), and plate (16). Discard lock washers.

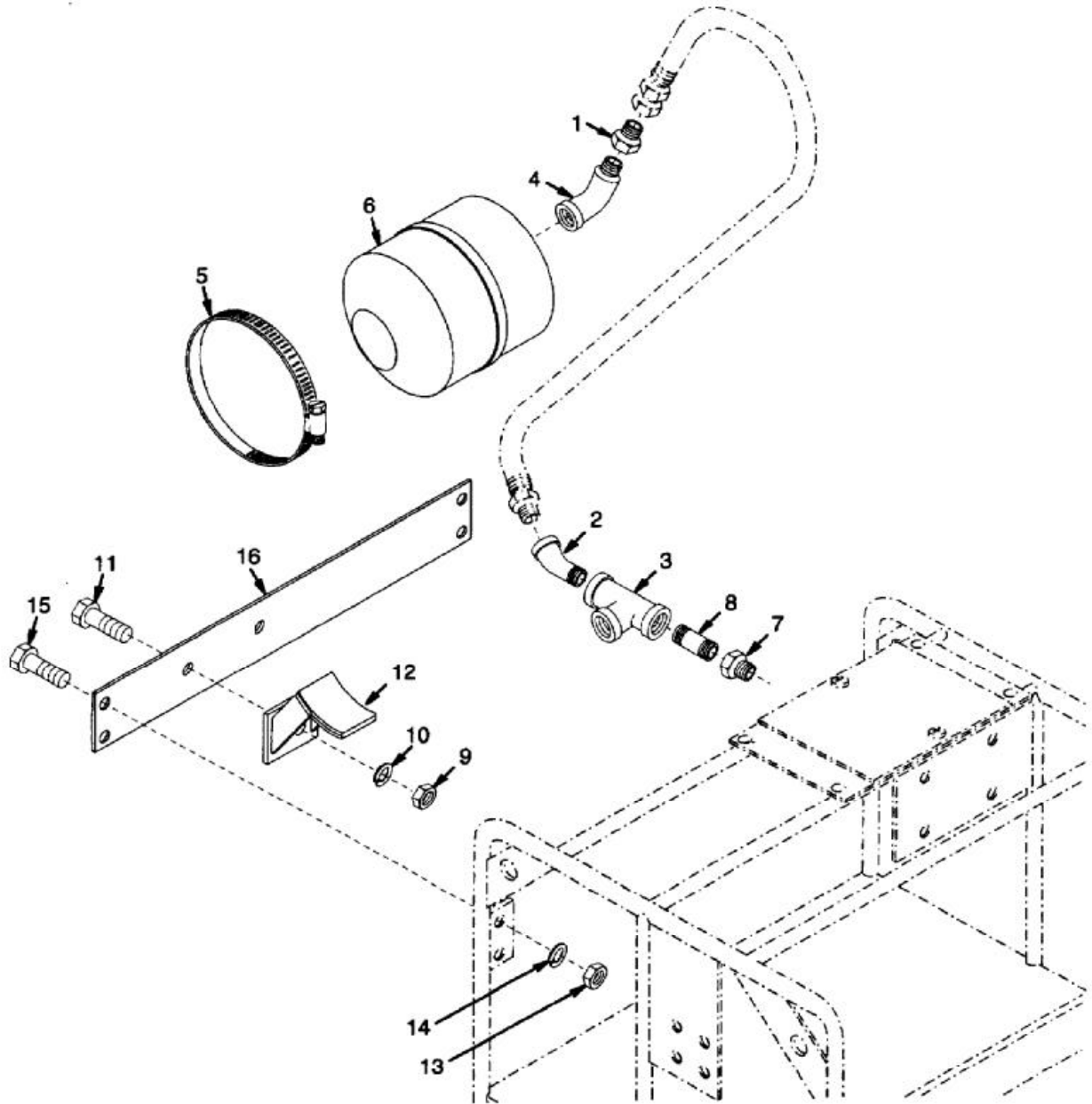

Figure 4-15. Diaphragm Tank & Fittings

4.17. DIAPHRAGM TANK & FITTINGS REPAIR OR REPLACEMENT. - CONTINUED

d. Assembly.

- (1) Be sure any defective, missing, or damaged components have been replaced.
- (2) Position plate (16) in place and align mounting holes then secure using four bolts (15), now lock washers (14), and nuts (13).

NOTE

The following procedure applies to both brackets. The quantities listed in the procedure are for one bracket only.

- (3) Position bracket (12) in place and align mounting holes then secure using bolt (11), new lock washer (10), and nut (9).
- (4) Apply sealing compound to threaded end (s) of nipple (8) and elbow (2) then assemble elbow, tee (3), nipple, and bushing (7).
- (5) Apply sealing compound to threaded end of bushing (4) then assemble elbow and bushing (1).

e. Installation.

- (1) Apply sealing compound to threaded ends of bushing (7) then install bushing with nipple (8), tee (3), and elbow (2) attached.
- (2) Install diaphragm tank (6) and secure using two clamps (5).
- (3) Apply sealing compound to diaphragm tank (6) fitting then install elbow (4) with bushing (1) attached.
- (4) Install cold line hose assembly onto bushing (1) and elbow (2). See paragraph 4.12.
- (5) Connect cold line hose assembly end onto tee (3). See paragraph 4.12.
- (6) Startup shower facility. See paragraph 2.7.

4.18. STORAGE CONTAINER REPAIR.

This task covers: a. Disassembly b. Assembly

INITIAL SETUPTools:

General Mechanics Tool Set (Appendix B, Section III, Item 1)

Equipment Conditions:

Storage container empty.

NOTE

Repair is limited to replacement of missing or damaged components. Disassemble only to the extent necessary to repair the item.

If the storage container must be replaced, notify direct support maintenance.

The following procedures can apply to multiple items. The quantities listed in the procedures are for only one item.

Refer to figure 4-16.

a. Disassembly.

- (1) Remove eight screws (1) and hinge (2).
- (2) Remove six screws (3) and latch (4).
- (3) Raise and support lid (5) then remove five screws (6), tee nuts (7), and bail handle (8).
- (4) Raise and support lid (5) then remove 10 screws (9), tee nut (10), and folding handle (11).
- (5) Replace any defective, missing, or damaged components.
- (6) If storage container was in use, place any removed items back in it.

b. Assembly.

- (1) Be sure any missing or damaged components have been replaced.
- (2) Raise and support lid (5) then position folding handle (11) in place and align mounting holes. Secure handle using five screws (9) and tee nuts (10).
- (3) Raise and support lid (5) then position bail handle (8) in place and align mounting holes. Secure handle using five screws (6) and tee nuts (7).
- (4) Position latch (4) in place and align mounting holes then secure using six screws (3).
- (5) Position hinge (2) in place and align mounting holes then secure using eight screws (1).
- (6) If storage container was in use, place any removed items back in it.

4.19. STORAGE CONTAINER REPAIR. - CONTINUED

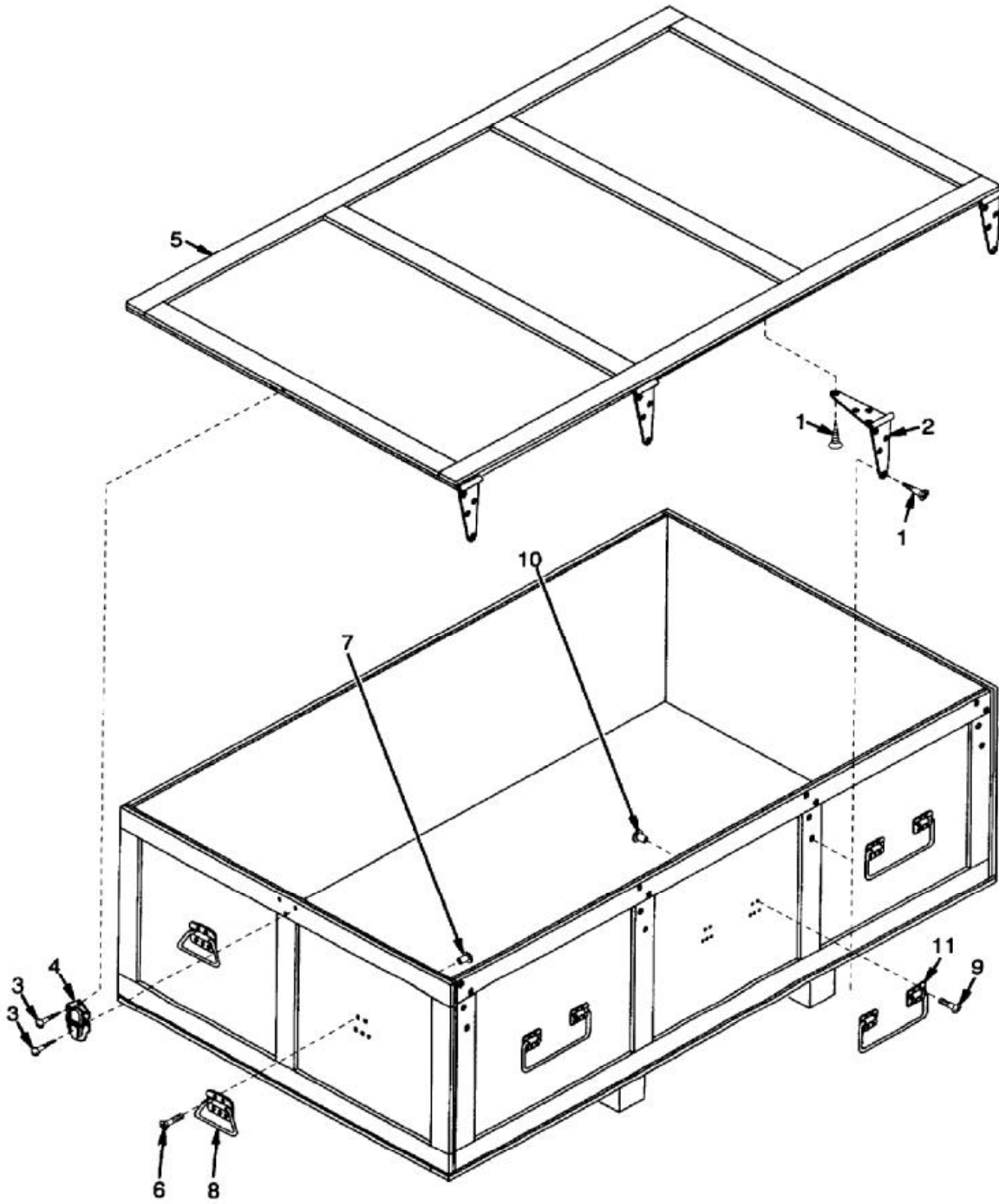

Figure 4-16. Storage Container

SECTION PREPARATION FOR STORAGE OR SHIPMENT

4.19. ADMINISTRATIVE STORAGE AND SHIPMENT.

a. Clean Shower Facility.

- (1) Using a bristle brush, scrub each soap dish, shower cover, and shower base to remove soap buildup. Rinse with clear water.
- (2) Using a bristle brush, scrub each floor panel to remove soap buildup. Rinse with clean water.
- (3) With portable shower module in an operational condition, open all shower nozzle assembly valves and allow water to run until water leaving drain hose is clear. Close all shower nozzle assembly valves.
- (4) Shut down the portable shower module (paragraph 2.7.).
- (5) Using a bristle brush, scrub floor mat to remove any dirt. Rinse with clear water.

b. Disconnect Power Cable.

WARNING

High voltage is used in the portable shower module. Care must be taken to avoid personal injury or death from energized circuits.

- (1) Be sure power source is de-energized then disconnect input power cable source.
- (2) Disconnect system power cable assembly connector from input power cable assembly plug.
- (3) Disconnect the system power cable assembly plug from the pump assembly input power connector.
- (4) Coil power cables neatly for storage.

Refer to figure 4-17.

c. Disconnect Hoses.

- (1) Disconnect two fuel hoses (1) from portable hot water system (2). Refer to technical manual covering the portable hot water system to find specific connection requirements for it.

NOTE

Hoses will contain water. Care must be taken to contain spills and minimize the task of slipping.

- (2) Disconnect supply hoses (3 and 4) from portable hot water system (2) and pump assembly (5).
- (3) Prepare the portable hot water system (2) for storage/shipment. Refer to technical manual covering the portable hot water system to find specific storage/shipment requirements for it.
- (4) Disconnect drain hose (6) from pump assembly (5) and wastewater connection point (storage tank), if connected to one.

4.19. ADMINISTRATIVE STORAGE AND SHIPMENT. – CONTINUED

- (5) Disconnect drain hose (7) from Y-fitting coupler (8) and pump assembly (5).
- (6) Disconnect two drain hoses (9) form Y-fitting coupler (8).
- (7) Disconnect and remove supply hose (10) from between regulator valve assembly (11) outlet and shower head manifold assembly (12).
- (8) Disconnect supply hose (13) ends over entrance to shower facility. Disconnect and remove six supply hoses from between each shower head manifold assemble (12) and install attached caps (14) onto manifold assembly ends.
- (9) Disconnect supply hose (15) from between pump assembly (5) and regulator valve assembly (11) inlet.
- (10) Disconnect supply hose (s) (16) from between pump assembly (5) and spring check valve assembly (17) or closed water supply as applicable.
- (11) Disconnect spring valve check assembly (17) and supply strainer (18) if being used.
- (12) Drain and thoroughly dry all hoses, fitting, and components. Coil hoses neatly for storage
- (13) Remove drain plug (19) from supply pump. Carefully tip pump assembly in all directions to drain water. When all water is drained, install drain plug.

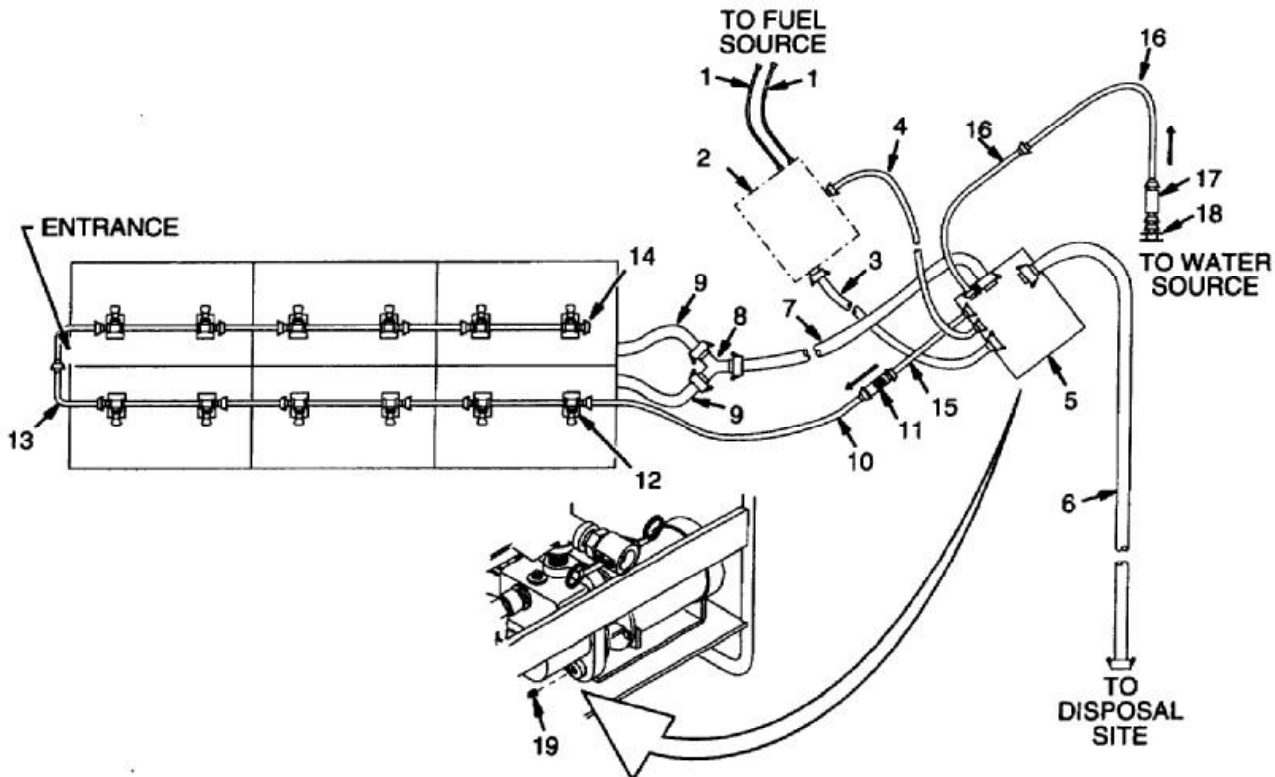

Figure 4-17. Disconnect Hoses

Refer to figure 4-18.

d. Disassemble Shower Facility.

- (1) Remove two door panels (1) from outside of shower facility. Fold door panels neatly for storage.

NOTE

The following procedures are typical for each shower base.

Three personnel required for disassembly.

- (2) Release hook and pile fasteners strips securing facing shower covers (2) to each other.
- (3) Release attached hook and pile fastener strips (3) securing facing top frame assemblies (4) to each other.
- (4) Release hook and pile fastener strips securing shower cover (2) to inside of shower base (5).
- (5) Release attached hook and pile fastener strips (6) securing shower cover (2) to vertical supports (7 and 8).
- (6) Remove vertical support (8).
- (7) From the inside, lift top frame assemble (4), off vertical supports (7) with shower cover (2) attached.
- (8) Release hook and pile fastener strips (9) securing shower cover (2) to top frame assembly (4). Remove shower cover form top frame assembly. Fold to frame assembly neatly for storage.
- (9) Remove five vertical supports (7).
- (10) Repeat above steps to disassemble remaining shower stalls.
- (11) Release hook and pile fastener strips and remove three floor panels (10).
- (12) Pull two sets of three shower bases (5) apart and carefully raise together to access drain hose assemblies (11).
- (13) Remove six drain hose assemblies (11) and install attached caps (12) onto an open end of each shower base (5) drain.
- (14) Carefully lower each shower base (5).

4.19. ADMINISTRATIVE STORAGE AND SHIPMENT. – CONTINUED

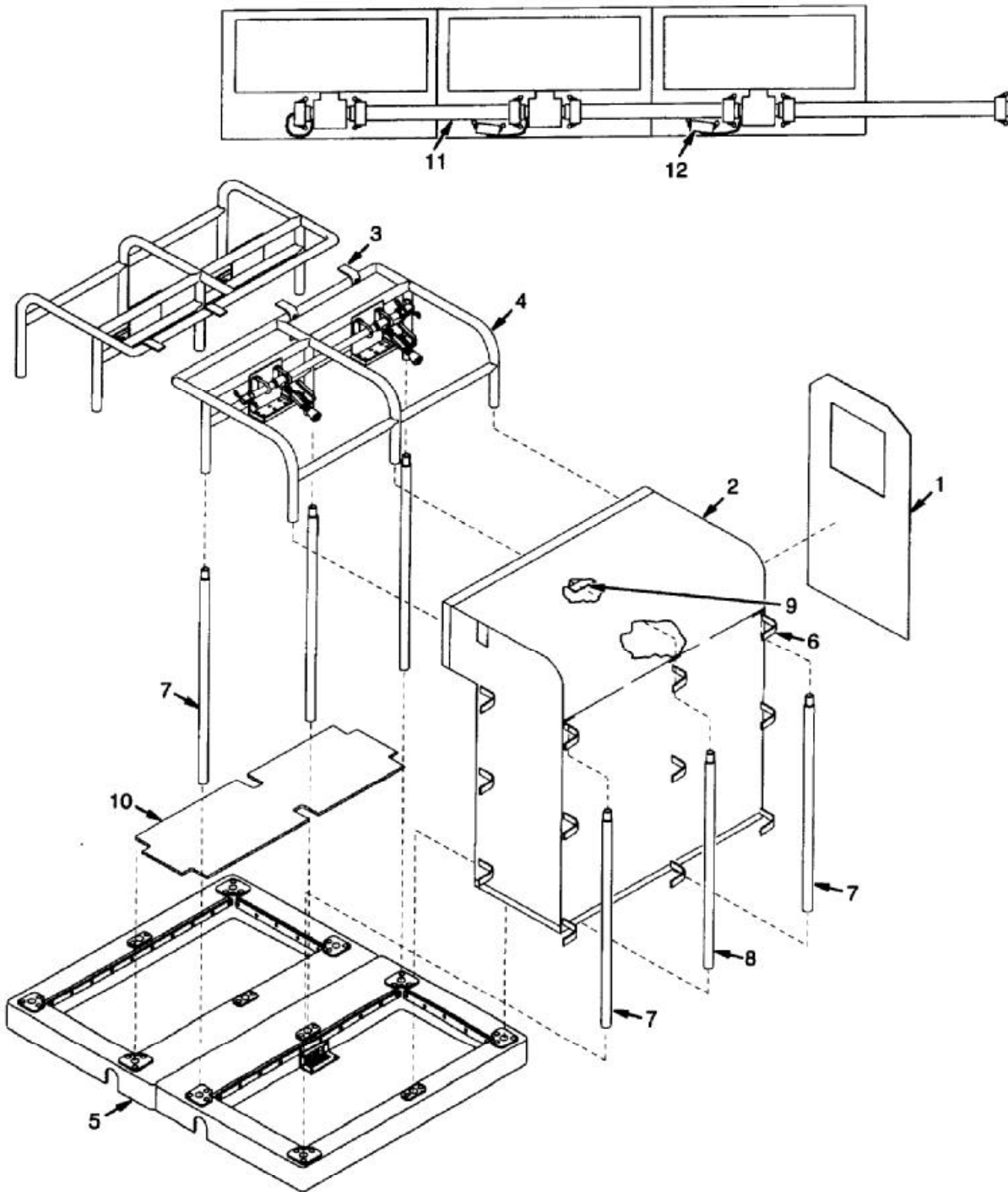

Figure 4-18. Shower Facility Disassembly

Table 4-3. Storage Container Contents

STORAGE CONTAINER 1		STORAGE CONTAINER 4	
Description of Contents	Quantity	Description of Contents	Quantity
Shower Base	1	Shower Base	1
Top Frame assembly	1	Top Frame Assembly	1
Vertical Supports	6	Vertical Supports	6
Shower Cover	1	Shower Cover	1
2 inch Drain Hose (5 feet long)	1	2 inch drain Hose (5 feet long)	1
1-1/2 inch Supply Hose (5 feet long)	1	1 inch Supply Hose (12 feet long)	1
2 inch Drain Hose (35 feet long)	1	Floor Mat	2
Regular Valve Assembly	1	Clinching Straps (2 on each floor mat)	4
STORAGE CONTAINER 2		STORAGE CONTAINER CONTENT 5	
Description of Contents	Quantity	Description of Contents	Quantity
Shower Base	1	Shower Base	1
Top Frame assembly	1	Top Frame Assembly	1
Vertical Supports	6	Vertical Supports	6
Shower Cover	1	Shower Cover	1
2 inch Drain Hose (5 feet long)	1	2 inch drain Hose (5 feet long)	1
1inch Supply Hose (25 feet long)	1	1 inch Supply Hose (35 feet long)	1
Y-Fitting coupler	1	Water Supply Strainer	1
Shower Heads (alternate)	12	System Power Cable Assembly	1
STORAGE CONTAINER 3		Input Power cable Assembly	1
		Spring Check Valve assembly	1
Description of Contents	Quantity	STORAGE CONTIANER 6	Quantity
Shower Base	1	Description of Contents	
Top Frame assembly	1	Shower Base	1
Vertical Supports	6	Top Frame assembly	1
Shower Cover	1	Vertical Support	6
2 inch Drain Hose (5 feet long)	1	Shower cover	1
1 inch Supply Hose	1	2 inch Drain Hose (5 feet long)	1
2 inch Drain Hose (35 feet long)	1	1 inch Supply Hose (2 feet long)	6
Floor Panels	3	1 inch Supply Hose (35 feet long)	1
Door Panels	2	Fuel Hose assemblies	2

4.20. ADMINISTRATIVE STORAGE AND SHIPMENT. – CONTINUED

- e. Pack Portable Shower Module.
 - (1) Prepare the hot water system for storage/shipment. Refer to manual covering the portable hot water system to find specific storage/shipment requirements for it.
 - (2) Roll up two floor mats and secure using two clinching straps on each mat.
 - (3) Remove all packaging material from storage containers.
 - (4) If assembly packaging was retained, package it as received.
 - (5) Place shower bases into storage containers first then package as necessary all remaining items for that container (see Table 4-3) and place neatly on top of it. If any components are damaged, notify supervisor.
 - (6) Close and secure storage containers.
- f. Ship/Store Portable Shower Module. Move pump assembly and storage containers to storage site or shipping point as applicable.

CHAPTER 5

DIRECT SUPPORT MAINTENANCE INSTRUCTIONS

5.1. POWER CABLE ASSEMBLIES REPAIR.

This task covers: a. Testing b. Disassembly c. Assembly

INITIAL SETUP

Tools:

General Mechanics Tool Set (Appendix B, Section III, Item 1).

Materials/Parts:

Sealing Compound (Appendix E, Item 1)
Marker Tags (Appendix E, Item 5)
ID /Straps (2) (Appendix G, Item 15)

General Safety Instructions:

WARNING

High voltage is used in the portable shower module. Care must be taken to avoid personal injury or death from energized circuits.

Refer to figure 5-1.

a. Testing.

- (1) Using multimeter set to measure continuity, check between each input power cable assembly loose lead and the corresponding contact point on the connector (1). Repair cable assembly if no continuity is indicated on any one lead.
- (2) Using multimeter set to measure continuity, check between system power cable assembly plug (2) contact points and the corresponding contact points on each connector (3 and 4). Repair cable assembly if no continuity is indicated on any lead.

NOTE

Repair is limited to replacement of missing or damaged components.
Disassemble only to the extent necessary to repair the item.

b. Disassembly.

- (1) Input Power Cable Assembly.
 - (a) Slipcover cap (5) off input power cable assembly.
 - (b) Remove connector (1).
 - (c) Remove two ID straps (6) from wire leads.
 - (d) Replace any damaged or missing components.

5.1. POWER CABLE ASSEMBLIES REPAIR. - CONTINUED

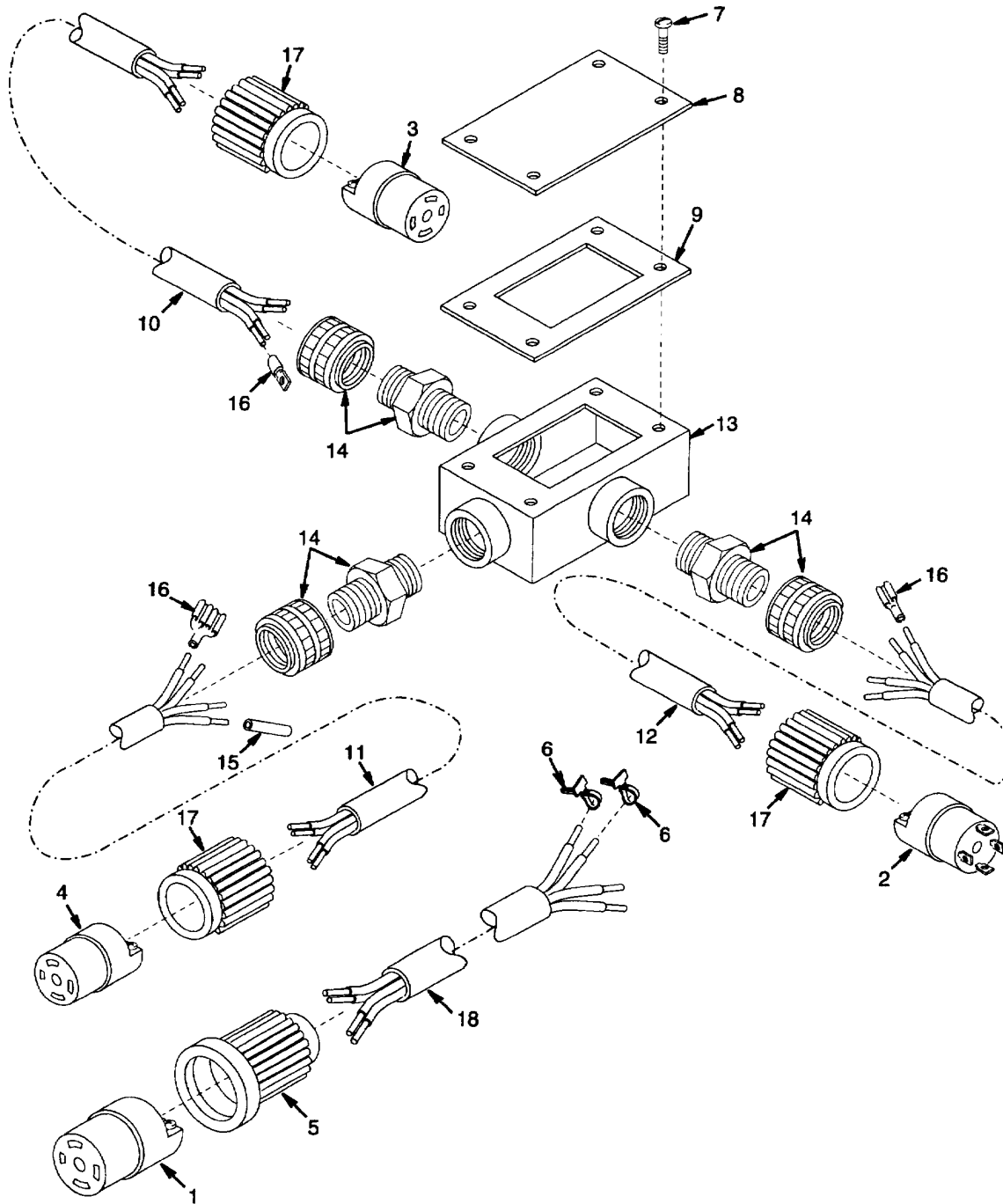

Figure 5-1. Power Cable Assembly

(2) System Power Cable Assembly.

NOTE

Gasket is supplied only with new box cover.

- (a) Remove four screws (7), cover (8), and gasket (9).
- (b) Tag and disconnect leads on cables (10, 11, and 12) inside box (13).
- (c) Loosen three cable connectors (14) and remove cables (10, 11, and 12). Remove cable connectors from box (13).
- (d) Remove heat shrink tubing (15) and crimp terminals (16) as necessary.
- (e) Slip one cover cap (17) off each cable (10, 11, and 12).
- (f) Remove plugs (3 and 4) from cables (10 and 11) and connector (2) from cable (12).
- (g) Replace any damaged or missing components.

c. Assembly.

(1) Input Power Cable Assembly.

- (a) Check that any damaged or missing components have been replaced.
- (b) Install ID strap (6) marked NEUTRAL onto white lead and ID strap marked GROUND onto green lead.
- (c) Check that insulation has been stripped from cable (18) as illustrated then install connector (1).
- (d) Slipcover cap (5) onto Cable (18) and over connector (1).

(2) System Power Cable Assembly.

- (a) Check that any damaged or missing components have been replaced.
- (b) Check that insulation has been stripped from cables (10, 11, and 12) as illustrated then install connector (2) onto cable (12) and plugs (3 and 4) onto cables (10 and 11).
- (c) Slip one cover cap (17) onto each cable (10, 11, and 12) and cover connector (2) and plugs (3 and 4).

5.1. POWER CABLE ASSEMBLIES REPAIR. – CONTINUED

- d. Install heat shrink tubing (15) and crimp terminals (16) as necessary.
 - (1) To install a crimp terminal on the end of a wire, be sure that $\frac{1}{4}$ - $\frac{1}{2}$ inch (0.6 – 1.3 cm) of insulation is stripped from the end of the wire. Insert wire end into the shank of the terminal then crimp the shank tightly onto the wire.
 - (2) To install heat shrink tubing. Slide the tubing over the wire before making the connection. After the connection is made, slide the tubing over the connection point and heat to shrink in place.
- e. Apply sealing compound to threaded end of each cable, connector (14) then install the three cable connectors into box (13).
- f. Install cables (10,11, and 12) into cable connectors (14) as illustrated. Tighten cable connectors onto cables.
- g. Connect leads on cables (10, 11, and 12) inside box (13) using tags. Install heat shrink tubing as necessary to insulate connection points.
- h. Apply sealing compound to threads of four screws (7) then install gasket (9), cover (8), and the four screws.

5.2. POWER CABLE ASSEMBLIES REPAIR.

This task covers: a. Disassembly b. Assembly

INITIAL SETUPTools:

General Mechanics Tool Set (Appendix B, Section III, Item 1).

Materials/Parts:

Sealing Compound (Appendix E, Item 1)
Lock Washers (8) (Appendix G, Item 10)

General Safety Instructions:

Supply pump assembly removed, paragraph 4.14.

General Safety instructions:**WARNING**

High voltage is used in the portable shower module. Care must be taken to avoid personal injury or death from energized circuits.

NOTE

Repair is limited to replacement of defective, missing, or damaged components. Disassemble only to the extent necessary to repair the item.

Refer to figure 5-2.

a. Disassembly.

- (1) Remove plugs (1 and 2).
- (2) Remove four screws (3) and lock washers (4). Discard lock washers.
- (3) Slide pump case (5) off pump side (6).
- (4) Carefully remove preformed packing (7) for use during assembly. If preformed packing is damaged, discard it.
- (5) Loosen and remove the impeller (8) by turning it counterclockwise. It may be necessary to strike the edge of the impeller with a rubber mallet as well as restrain the cooling fan located in the back of the motor (9) to loosen it.
- (6) Remove shims (10 and 11).

5.2. SUPPLY PUMP ASSEMBLY REPAIR. - CONTINUED

NOTE

The seal is supplied as a complete assembly but is made up of a rotating and stationary portion. The seal must be replaced as a complete matched assembly.

- (7) Remove the rotating portion of the seal (12).
- (8) Remove four screws (13) and lock washers (14). Discard lock washers.
- (9) Separate motor (9) and pump side (6) then remove slinger (15).
- (10) Remove stationary portion of seal (12) by carefully pushing it out from the back of pump side (6).
- (11) Replace any damaged or missing components.

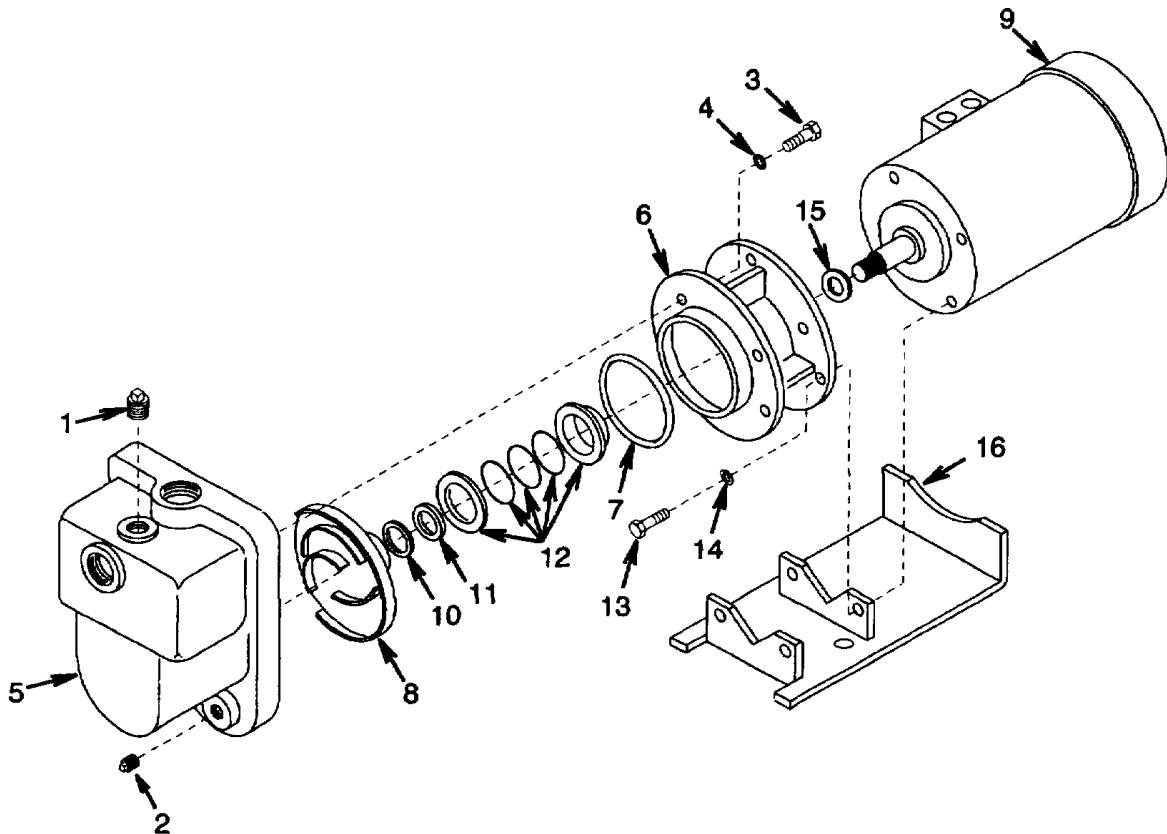

Figure 5-2. Supply Pump Assembly

b. Assembly.

- (1) Check that any damaged or missing components have been replaced.

CAUTION

The use of petroleum-based lubrications on the seal could cause it to slip out of place while in use.

- (2) Install stationary portion of seal (12) by carefully pushing it into the pump side (6). Be sure the ceramic seal seat is facing out to mate with the rotating portion of the seal when installed. Wet the seal with water or saliva as appropriate to aid in assembly but do not use a petroleum-based lubricant.
- (3) Install slinger (15) onto motor (9) shaft then assemble motor and pump side (6) being careful not to damage stationary portion of seal (12).

NOTE

A drain slot is provided in the bottom of the motor end of the pump side.

- (4) Place motor (9), with pump side (6) installed, onto base (16). Be sure pump side is positioned with the drain slot pointed down and the motor is positioned with conduit connector pointed up. Align the mounting holes in the motor, pump side, and base then secure using four new lock washers (14) and bolts (13).
- (5) Carefully slide the rotating portion of seal (12) onto motor (9) shaft. Be sure the carbon surface of the rotating portion is facing toward the ceramic seal seat of the stationary portion.

NOTE

Shims are supplied and installed in two different thicknesses, 0.005 and 0.010 inch.

- (6) Install shims (10, and 11) then install impeller (8). Check axial clearance between the impeller and pump face. Clearance should be between 0.015 and 0.020 inch. In necessary, remove impeller then ass or remove shims as necessary to achieve the necessary clearance.
- (7) Install preformed packing (7) then slide pump case (5) onto pump side (6). Align mounting holes and install four new lock washers (4) and screws (3).
- (8) Apply sealing compound to threads of plugs (1 and 2) then install plugs.

5.2. DIAPHRAGM (DRAIN) PUMP ASSEMBLY REPAIR.

This task covers: a. Disassembly b. Assembly

INITIAL SETUP

Tools:

General Mechanics Tool Set (Appendix B, Section III, Item 1).

Equipment Conditions:

Diaphragm (drain) pump assembly removed, paragraph 4.16.

Materials/Parts:

Lock Washers (10) (Appendix G, Item 11)
Lock Washers (4) (Appendix G, Item 12)
Lock Washers (4) (Appendix G, Item 13)
Sealing Washers (2) (Appendix G, Item 14)
Multipurpose Grease (Appendix E, Item 3)

General Safety Instructions:

WARNING

High voltage is used in the portable shower module. Care must be taken to avoid personal injury or death from energized circuits.

NOTE

Repair is limited to replacement of defective, missing, or damaged components. Disassemble only to the extent necessary to repair the item.

Refer to figure 5-3.

a. Disassembly.

- (1) Remove four nuts (1), lock washers (2), screws (3), and pump base (4). Discard lock washers.

NOTE

Note orientation of discharge chamber and check valve assembly for use during assembly.

- (2) Remove four nuts (5), screws (6), discharge chamber (7), and carefully remove check valve assembly (8) for use during assembly. If check valve assembly is damaged, discard it.
- (3) Remove four nuts (9), screws (10), suction chamber (11), and carefully remove check valve assembly (12) for use during assembly. If check valve assembly is damaged, discard it.
- (4) Remove snap ring (13).
- (5) Remove two screws (14), lock washers (15), sealing washers (16), pump support plate (17), diaphragm (18), and eccentric housing (19). Discard lock washers and sealing washers.
- (6) Remove cap (20) and grease fitting (21).
- (7) Remove eccentric disk (22) and key (23).
- (8) Remove four screws (24), lock washers (25), and motor (26). Discard lock washers.

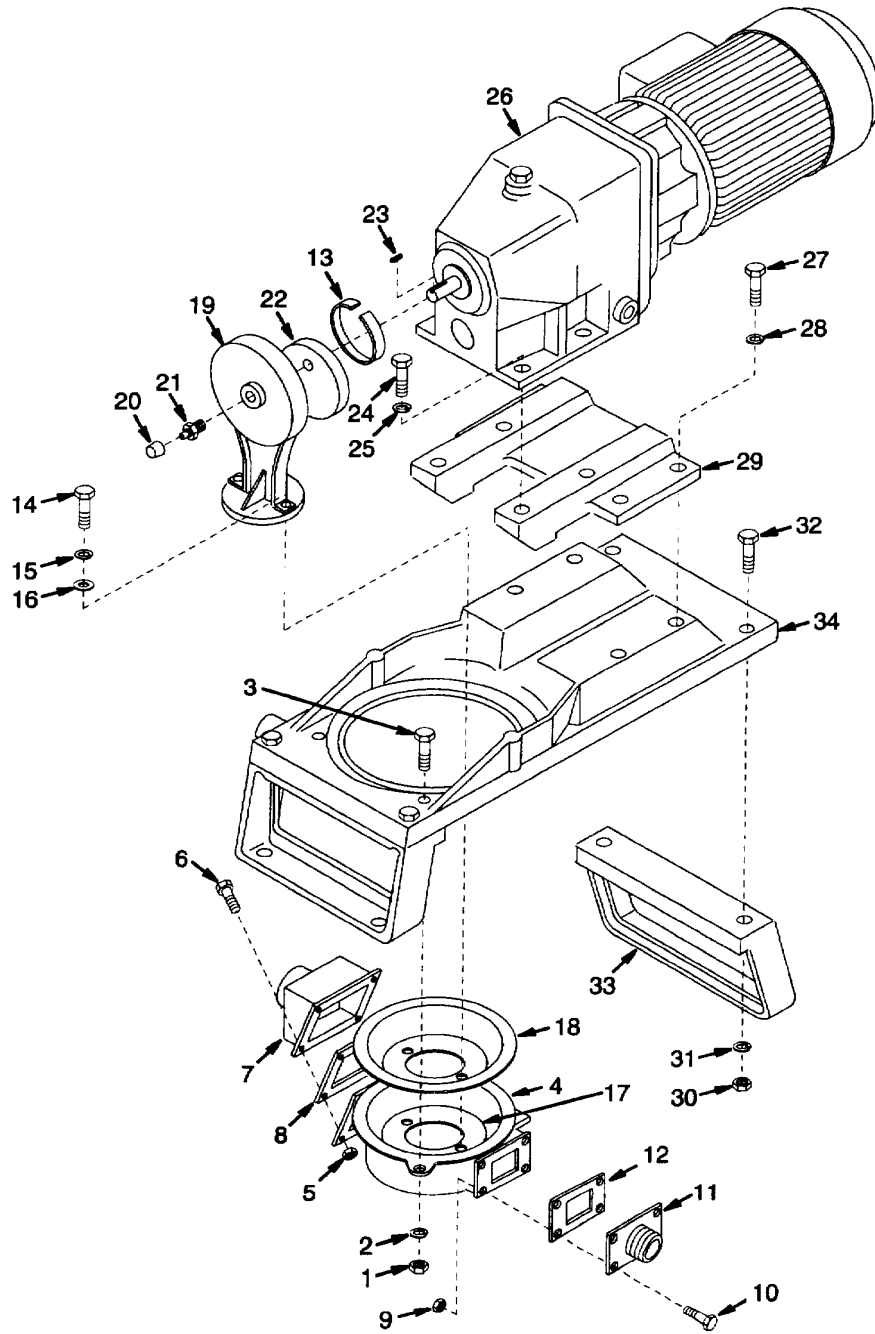

Figure 5-3. Diaphragm (Drain) Pump Assembly

5.3. DIAPHRAGM (DRAIN) PUMP ASSEMBLY REPAIR. - CONTINUED

- (9) Remove four screws (27), lock washers (28), and plate (29). Discard lock washers.
- (10) Remove four nuts (30), lock washers (31), screws (32), and two legs (33). Discard lock washers.
- (11) Replace any damaged or missing components.
 - b. Assembly.
 - (1) Check that any damaged or missing components have been replaced.
 - (2) Position two legs (33) under frame (34) and align mounting holes. Secure using four screws (32), new lock washers (31), and nuts (30).
 - (3) Place plate (29) on frame (34). Align mounting holes and secure using four new lock washers (28) and screws (27).
 - (4) Place motor (26) on plate (29). Align mounting holes and secure using four new lock washers (25) and screws (24).
 - (5) Install key (23) onto motor (26) shaft then install eccentric disk (22).
 - (6) Install grease fitting (21) and cap (20).
 - (7) Place eccentric housing (19) over eccentric disk (22) then secure using snap ring (13).
 - (8) Assemble support plate (17) and diaphragm (18) then align mounting holes with eccentric housing (19) and secure using two new sealing washers (16), new lock washers (15) and screws (14). Be sure diaphragm is under frame (34).
 - (9) Assemble suction chamber (11) and check valve assembly (12) then place against pump base (4). Align mounting holes and secure using four screws (10) and nuts (9).

NOTE

Be sure to orient check valve assembly and discharge chamber as noted during disassembly. Large counterweight (large metal plate) on check valve assembly faces discharge flow direction.

- (10) Assemble discharge chamber (7) and check valve assembly (8) then place against base (4). Align mounting holes and secure using four screws (6) and nuts (5).
- (11) Place pump base (4) under frame (34) with diaphragm (18) between base and frame. Align mounting holes and secure using four screws (3), new lock washers (2), and nuts (1). Be sure diaphragm is not pinched.

5.3. PUMP ASSEMBLY FRAME REPLACEMENT.

This task covers: a. Disassembly b. Assembly

INITIAL SETUPTools:

General Mechanics Tool Set (Appendix B, Section III, Item 1).

Materials/Parts:

Pump assembly removed form system, paragraph 4.19.

General Safety Instructions:**WARNING**

High voltage is used in the portable shower module. Care must be taken to avoid personal injury or death from energized circuits.

NOTE

Repair of the pump assembly frame requires removal of all components.

Refer to figure 5-4.

b. Disassembly.

- (1) Remove supply cold pump line hose assemblies. See paragraph 4.12.
- (2) Remove switch box assembly. See paragraph 4.13.
- (3) Remove supply pump assembly. See paragraph 4.14.
- (4) Remove regulator assembly. See paragraph 4.15.
- (5) Remove diaphragm (drain) pump assembly. See paragraph 4.16.
- (6) Remove diaphragm tank and fittings. See paragraph 4.16.
- (7) Remove six screws (1) and mounting plate (2) with instruction plate (3) attached.

NOTE

The instruction plate has adhesive backing and is secured to the mounting plate. If the instruction plate is removed, it cannot be used again and must be replaced.

- (8) If instruction plate (3) needs to be replaced, remove it form the mounting plate (2). If the mounting plate needs to be replaced, discard both.
- (9) Send pump assemble frame (4) to general support maintenance for repair.

5.4. PUMP ASSEMBLY FRAME REPLACEMENT. – CONTINUED

b. Assembly.

- (1) If the instruction plate (3) was removed from the mounting plate (2), peel paper backing off new instruction plate then secure mounting holes align and carefully secure it to the instruction plate.
- (2) Place mounting plate (2), with instruction plate (3) attached, onto pump assembly frame (4). Align mounting holes and secure using six screws (1).
- (3) Install supply pump cold line hose assemblies See paragraph 4.12.
- (4) Install switch box assembly. See paragraph 4.13.
- (5) Install supply pump assembly. See paragraph 4.14.
- (6) Install regulator assembly. See paragraph 4.15.
- (7) Install diaphragm (drain) pump assembly. See paragraph 4.16.
- (8) Install diaphragm tank and fittings. See paragraph 4.16.

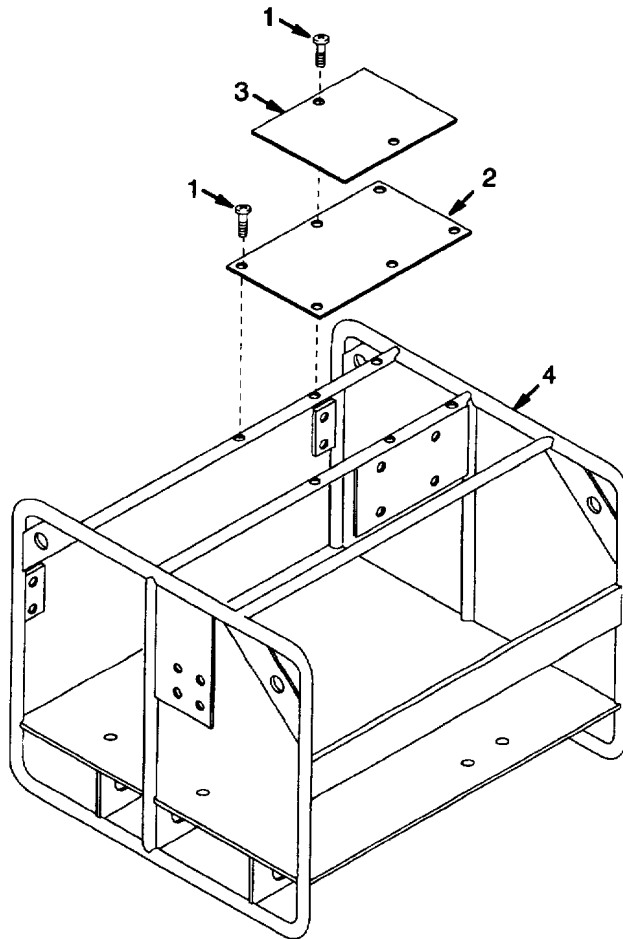

Figure 5-4. Pump Assembly Frame

5.5. STORAGE CONTAINER REPLACEMENT.

This task covers: a. Disassembly b. Assembly

INITIAL SETUP

Tools:

General Mechanics Tool Set (Appendix B, Section III, Item 1).
 Drill (Appendix B, Section III, Item 3)
 Drill Set (Appendix B Section III, Item 3)

General Safety Instructions:

Storage container empty.

NOTE

Salvaging usable hardware items from the old storage container is the only disassembly applicable to replacing the container.

- a. Disassembly. Remove any usable hardware items from the old storage container. See paragraph 4.18. Replace any un-usable or missing hardware items to make a complete set for assembly.

NOTE

Replacement of the storage container consist of assembling a new container using salvaged or new hardware and bulk lumber and plywood.

- b. Assembly.

- (1) Fabricate Lid. Place two pieces of lumber (1) (Appendix F, Figure F-6 Item 4) and four equally spaced pieces of lumber (2) (Appendix F, Figure F-6 Item 5) onto one sheet of plywood (3) (Appendix f, Figure F-7, Item 4) as illustrated. Secure the lumber to plywood using construction staples, nails, or glue as available.

- (2) Fabricate Box.

- (a) Bottom Panel. Place two pieces of lumber (4) Appendix F, figure F-6, Item 4) and four equally spaced pieces of lumber (5) (Appendix F, Figure F-6, Item 5) onto sheet of plywood (6) (Appendix F, Figure F-7, Item 4) then place two pieces of lumber (7) (Appendix F, Figure F-6, Item 6) onto centerpieces of lumber (5) as illustrated. Secure the lumber to plywood using construction staples, nails, or glue as available. Turn bottom over so it is supported by the two pieces of lumber (7) as illustrated.

NOTE

The following procedure applies to both panels. The quantities listed are for one panel only.

- (b) Front/Back Panels. Place two pieces of lumber (8) (Appendix F, figure F-6, Item 4) and four equally spaced pieces of lumber (9) (Appendix F, Figure F-6, Item 1) onto one sheet of plywood (10) (Appendix F, Figure F-7, Item 3) as illustrated. Secure the lumber to plywood using construction staples, nails, or glue as available.

5.5. STORAGE CONTAINER REPLACEMENT. – CONTINUED

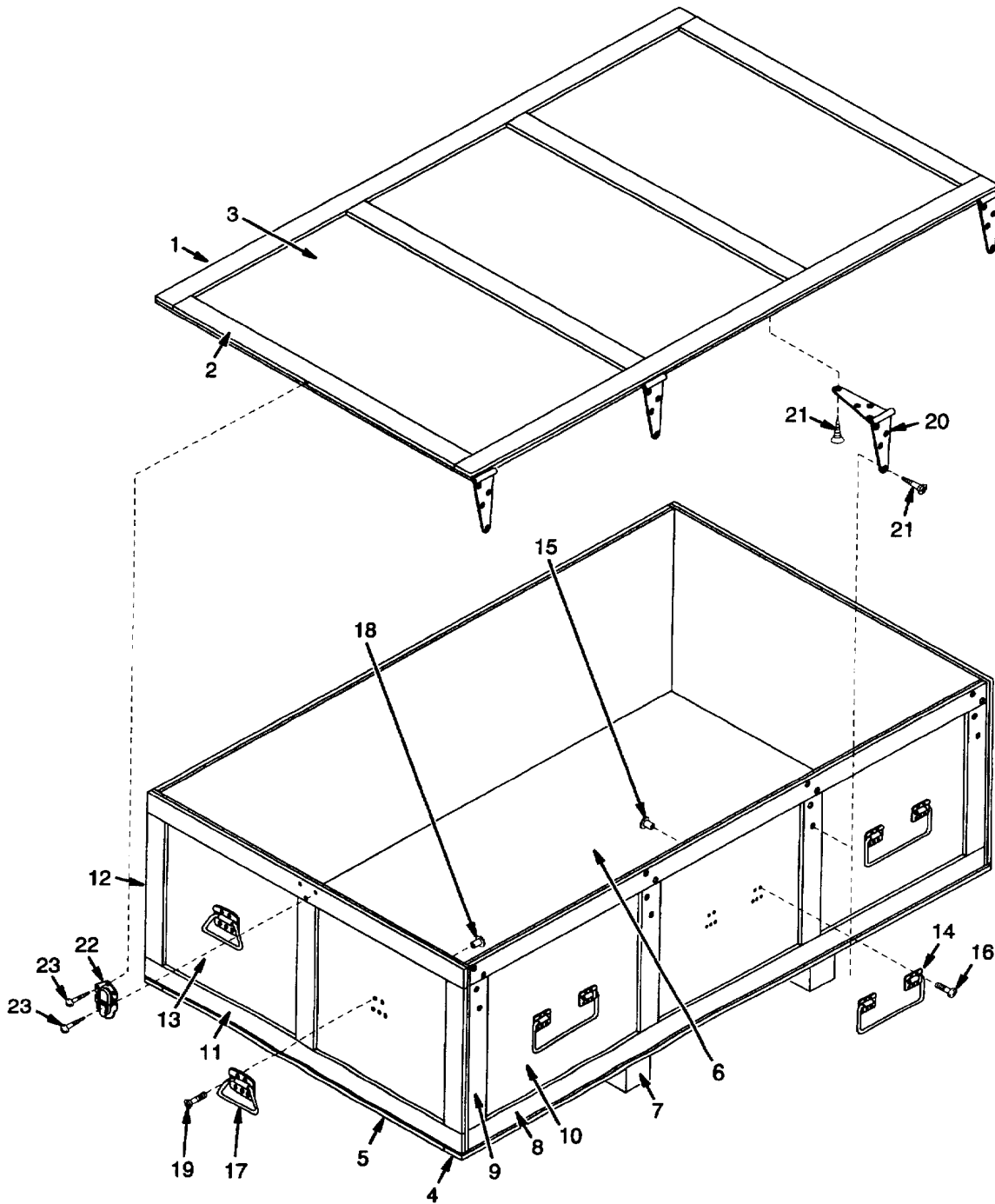

Figure 5-5. Storage Container

NOTE

The following procedure applies to both panels. The quantities listed are for one panel only.

- (c) Left/Right Side Panels. Place two pieces of lumber (11) (Appendix F, Figure F-6, Item 3) and three equally spaced pieces of lumber (12) (Appendix F, Figure F-6, Item 1) onto one sheet of plywood (13) (Appendix F, Figure F-7, Item 2) as illustrated. Secure the lumber to plywood to using construction staples, nails, or glue as available.
- (d.) Assemble the front, back, left, and right side panels onto the bottom panel as illustrated. Secure the panels to bottom and each other using construction staples, nails, or glue as available.

NOTE

The following procedures apply to multiple items. The quantities listed in the procedures are for only one item.

- (3) Position folding handle (14) in place as illustrated and mark mounting hole locations. Drill 10 mounting holes necessary and insert 10 tee nuts (15) form inside box. Position folding handle in place and align mounting holes then secure 10 screws (16). Repeat procedure for remaining five folding handles
- (4) Position bail handle (17) in place as illustrated and mark mounting hole locations. Drill five mounting holes a necessary and insert five tee nuts (18) form inside box. Position bail handle in place and align mounting holes then secure using five screws (19). Repeat procedure for remaining three bail handles.
- (5) Place lid on box and position hinge (20) in place as illustrated. Mark mounting hole locations and drill eight pilot holes (four in lid and four in box). Position hinge in place and align mounting holes then secure using eight screws (21) (four in lid and four in box). Repeat procedure for remaining three hinges.
- (6) Position latch (22) in place as illustrated. Mark mounting holes locations and drill six pilot holes (three in lid and three in box). Position latch in place and align mounting holed then secure using six screws (23) (three in lid and three in box). Repeat procedure for remaining two latches.

THIS PAGE INTENTIONALLY LEFT BLANK

CHAPTER 6

GENERAL SUPPORT MAINTENANCE INSTRUCTIONS

6.1. POWER CABLE ASSEMBLIES REPAIR.

This task covers: Repair

INITIAL SETUP

Tools:

Welding Tool Set (Appendix B, Section III, Item 4)

Equipment Conditions:

All components removed from pump assembly frame.

Materials/Parts:

Lusterless Enamel (Appendix E, Item 4)

NOTE

Repair is limited to welding any crack or broken seams as well as any dents or bends in the assembly frame.

Repairs.

- (1) Repair any minor dents or bends in the frame using common sheet metal repair procedures.
- (2) Remove paint from any surface being welded then repair using common welding procedures.
- (3) Paint any welded surfaces, or areas where paint has been removed, using lusterless enamel paint as necessary.

THIS PAGE INTENTIONALLY LEFT BLANK

APPENDIX A REFERENCES

A.1. SCOPE.

This appendix list all forms, field manuals, and technical manuals referenced in this manual.

A.2. FORMS.

Recommended Changes to Publications	DA Form 2028
Recommended Changes to Equipment Technical Manuals	DA Form 2028-2
Equipment Inspection and Maintenance Worksheet.....	DA form 2404
Equipment Control Record.....	DA fro0m 2408-9
Product Quality Deficiency Report.....	Standard Form 368

A.3 TECHNICAL MANUALS.

Destination of Army Materials to Prevent Enemy Use	TM 750-244-3
Unit, Direct Support, and General Support Maintenance Repair Parts and Special Tools List.....	TM 10-4510-207-24P

A.4. MISCELLANEOUS PUBLICATIONS.

Army Maintenance Management System (TAMMS)	DA Pam 738-750
Expendable Items (Except Medical Class V, Repair Parts and Heraldic Items)	CTA 50-970
Army Medical Department Expendable/Durable Items.....	CTA 8-100

THIS PAGE INTENTIONALLY LEFT BLANK

APPENDIX B MAINTENANCE ALLOCATION CHART

SECTION I INTRODUCTION

B.1. GENERAL

B.1.1. This section provides a general explanation of all maintenance and repair functions authorized at various maintenance categories.

B.1.2. The Maintenance Allocation Chart (MAC) in Section II designates overall authority and responsibility for performance of maintenance functions on the portable shower module. The application of the maintenance functions to the end item or component will be consistent with the capacities and capabilities of the designed maintenance categories.

B.1.3. Section III lists the tools and test equipment (both special tools and common tool sets) required for each maintenance function as referenced from Section II.

B.1.4. Section IV contains supplemental instructions and explanatory notes for a particular maintenance function.

B.2. MAINTENANCE FUNCTIONS.

Maintenance functions will be limited to and defined as follows:

B.2.1. Inspect. To determine the serviceability of an item by comparing its physical, mechanical and/or electrical characteristics with established standards through examination (e.g., by sight, sound, or feel).

B.2.2. Test. To verify serviceability by measuring the mechanical, pneumatic, hydraulic, or electrical characteristics of an item and comparing those characteristics with prescribed standards.

B.2.3. Service. Operations required periodically to keep an item in proper operation condition, i.e, to clean (includes decontaminate when required), to preserve, to drain, to paint, or to replenish fuel, lubricants, chemical fluids, or gases.

B.2.4. Adjust. To maintain or regulate, within prescribed limits, by bringing into proper or exact position, or by setting the operating characteristics to specified parameters.

B.2.5. Aline. To adjust specified variable elements of an item to bring optimum performance

B.2.6. Calibrate. To determine and cause corrections to be made or to be adjusted in instruments or test, measuring, and diagnostic equipment used in precision measurement. Consists of comparisons of two instruments, one of which is a certified standard of known accuracy, to detect and adjust any discrepancy in the accuracy of the instrument being compared.

B.2.7. Remove/Install. To remove and install the same item when required to perform service or other maintenance functions. Install may be the act of emplacing, seating, or fixing into position a spare, repair part, or module (component or assembly) in manner the proper function of an equipment or system.

B.2. MAINTENANCE FUNCTIONS. CONTINUED

B.2.8. Replace. To remove an unserviceable item and install a serviceable counterpart in its place. "Replace" is authorized by the MAC and is shown as the 3rd position code of the SMR code.

B.2.9. Repair. The application of maintenance services, including fault location/troubleshooting, removal/installation, and disassembly/ assembly procedures, and maintenance actions to identify troubles and restore serviceability to an item by correcting specific damage, fault, malfunction, or failure in a part, subassembly, module (component or assembly), end item, or system.

B.2.10. Overhaul. That maintenance effort (service/action) prescribed to restore an item to a completely serviceable/operational condition as required by maintenance standards. In appropriate technical publications (i.e., DMWR). Overhaul is normally the highest degree of maintenance performed by the Army. Overhaul does not normally return an item to like new condition.

B.2.11. Rebuild. Consists of those services/actions necessary for the restoration of unserviceable equipment to a like new condition in accordance with original manufacturing standards. Rebuild is the highest degree of material maintenance applied to Army equipment. The rebuild operation includes the act of returning to zero those age measurements (e.g., hours/miles, ect.) considered in classifying Army equipment/components.

B.3. EXPLANATION OF COLUMNS IN THE MAC, SECTION II.

B.3.1. Column 1, Group Number. Column 1 lists functional group code numbers, the purpose of which is to identify maintenance significant components, assemblies, subassemblies, and modules with next higher assembly. End item group numbers are "00".

B.3.2. Column 2, Component/Assembly. Column 2 contains the names of components, assemblies, subassemblies, and modules for which maintenance is authorized.

B.3.3. Column 3, Maintenance Functions. Column 3 lists the functions to be performed on the item listed in column 2. (For detailed explanation of these functions, see paragraph B-2.)

B.3.4. Column 4, Maintenance Level. Column 4 specifies, by the listing of a work time figure (expressed as man-hours shown as whole hours or decimals) in the appropriate subcolumn (s), the level of maintenance authorized to perform the function listed in Column (3). This figure represents the active time required to perform that maintenance function at the indicated level of maintenance. If the number or the complexity of the tasks within the listed maintenance level function vary at different maintenance levels, appropriate work time figures will be shown for each level. The work time figure represents the average time required to restore an item (assembly, subassembly, component, module end item, or system) to a serviceable condition under typical field operating conditions. This time includes preparation item (including any necessary disassembly/assembly time), troubleshooting/fault location time, and quality assurance/quality control time in addition to the time required to perform the specific tasks identified for the maintenance functions authorized in the maintenance allocation chart. The system designations for the various maintenance levels are shown on the following page.

C.....	Operator or crew
O.....	Unit Maintenance
F.....	Direct Support Maintenance
H.....	General Support Maintenance
D.....	Depot Maintenance

B.3.5. Column 5, Tools and Equipment. Column 5 specifies, by code, those common tool sets (not individual tools) common TMDE, and special tools, special TMDE, and special supports equipment required to perform the designated function.

B.3.6. Column 6, Remarks. This column, when applicable, contains a letter code, in alphabetical order, which is keyed to the remarks contained on Section IV.

B.4. EXPLANATION OF COLUMNS IN TOOL AND TEST EQUIPMENT REQUIREMENTS, SECTION III.

B.4.1. Column 1, Reference Code. The tool and test equipment reference code correlates with a code used in the MAC, Section II, Column 5.

B.4.2. Column 2, Maintenance Level. The lowest category of maintenance authorized to use the tool or test equipment.

B.4.3. Column 3, Nomenclature. Name or identification of the tool or test equipment.

B.4.4. Column 4, National Stock Number. The National stock number of tool or test set.

B.4.5. Column 5, Tool Number. The manufacturer's part number or type number.

B.5. EXPLANATION OF COLUMNS IN REMARKS, SECTION IV.

B.5.1. Column 1, Reference Code. The code recorded in column 6, Section II.

B.5.2. Column 2, Remarks. This column lists information pertinent to the maintenance function being performed as indicated in the MAC, Section II.

**SECTION II MAINTENANCE ALLOCATION CHART FOR
PORTABLE SHOWER MODULE**

(1) Group Number	(2) Component/Assembly	(3) Maintenance Function	(4) Maintenance Category					(5) Tools & Equip.	(6) Remarks
			Unit		DS	GS	Depot		
			C	O	F	H	D		
00	PORTABLE SHOWER MODULE								
01	LOOSE ITEMS								
	Loose Items	Inspect Replace	0.1 0.2					A	
	Power Cable Assembly	Inspect Test Replace Repair	0.1	0.1 0.2 0.5	0.2 1.0		1, 2	B	

**SECTION II MAINTENANCE ALLOCATION CHART FOR
PORTABLE SHOWER MODULE - CONTINUED**

(1) Group Number	(2) Component/Assembly	(3) Maintenance Function	(4) Maintenance Category					(5) Tools & Equip.	(6) Remarks
			Unit		DS	GS	Depot		
			C	O	F	H	D		
02	MISCELLANIOUS ASSEMBLIES								
	Portable Shower Base	Inspect Repair Replace	0.1	0.1 1.0 0.5				1	B
	Top Frame Assembly	Inspect Repair Replace		0.1 1.0 0.5				1	B
	Strain Assy	Inspect Repair Replace		0.1 0.5 0.2				1	B
	Spring Check Valve Assy	Inspect Repair Replace		0.1 0.5 0.2				1	B
	Regulator Valve Assy	Inspect Repair Replace		0.1 0.5 0.2				1	B
	Hose Assemblies	Inspect Repair Replace	0.1	0.1 0.8 0.2				1	B
03	WATER PUMP ASSEMBLY	Inspect	0.1						
	Cold Line Wire Assemblies	Inspect Repair Replace		0.1 0.8 0.2				1	B
	Switch Box Assembly	Inspect Test Repair Replace		0.5 0.8 1.0 0.8				1, 2	B
	Supply Pump Assembly	Inspect Repair Replace		0.1 1.5	2.0			1	B
	Regulator Assembly	Inspect Repair Replace		0.1 1.0 0.8				1	B

**SECTION II MAINTENANCE ALLOCATION CHART FOR
PORTABLE SHOWER MODULE - CONTINUED**

(1) Group Number	(2) Component/Assembly	(3) Maintenance Function	(4) Maintenance Category					(5) Tools & Equip.	(6) Remarks
			Unit		DS	GS	Depot		
			C	O	F	H	D		
03	WATER PUMP ASSEMBLIES-Continued								
	Diaphragm Pump	Inspect Repair Replace	0.1	0.1 0.1	2.0			1 B	
	Diaphragm Tank & Fitting	Inspect Repair Replace	0.1	0.1 1.0 1.0				1 B	
	Pump Frame	Inspect Repair Replace	0.1		6.0	1.0		1, 3 B	
04	STORAGE CONTAINER								
	Storage Container	Inspect Repair Replace	0.1	2.0	6.0			1 B	

**SECTION III TOOLS AND TEST EQUIPMENT FOR
PORTABLE SHOWER MODULE**

(1) REFERENCE CODE	(2) MAINTENANCE LEVEL	(3) NOMENCLATURE	(4) NATIONAL STOCK NUMBER (NSN)	(5) TOOL NUMBER
1	O	Tool Set, General Mechanic's	5180-00-699-5273	SC 5180-90-CL-NO5
2	O	Shop Equipment, Automotive Maintenance and Repair: Organizational Maintenance, Common, NO 1	4910-00-754-0654	SC 4910-95-A74
3	F	Shop Equipment, automotive Maintenance and Repair: Field Maintenance, Basic, Less Power	4910-00-754-0705	SC 4940-95-CL-A64
4	H	Shop Equipment, Welding	4940-00-209-6240	SC 4940-95-CL-A64

SECTION IV REMARKS FOR PORTABLE SHOWER MODULE

Reference Code	Remarks
A	Loose items consist of the following: Y-fitting coupler, door panel, shower cover, floor mat, floor panel, and vertical support.
B	All repair and replacement of parts performed by organizational maintenance limited to authorized items in TM 10-4510-207-24P

APPENDIX C COMPONENTS OF END ITEM (COEI) AND BASIC ISSUE ITEMS LIST (BII)

SECTION I INTRODUCTION

C.1. SCOPE

This appendix list components of the end item and basic issue for the portable shower module to help you inventory the items for safe and efficient operation of the equipment.

C.2. GENERAL.

The Components of the End Item (CEOI) and Basic Issue Items (BII) Lists are divided into the following sections:

C.2.1. Section II, Components of the End Item. This listing is for information purposes only, and is not authority to requisition replacements. These items are part of the portable shower module. As part of the end item, these items must be with the end item whenever it is issued or transferred between property accounts. Items of CEOI are removed and separately packed for transportation or furnished to help you find and identify the items.

C.2.2. Section III, Basic Issue Items. These essential items are required to place the portable shower module in operation, operate it, and to do emergency repairs. Although shipped separately packed, BII must be with the portable shower module during operation and when it is transferred between property accounts. This list is your authority to request/requisition them for replacement based on authorization of the end item by the TOE/MTOE. Illustrations are furnished to help you find and identify the items.

C.3. EXPLANATION OF COLUMNS.

C.3.1. Column (1), Illus Number, give you the number of the item illustrated.

C.3.2. Column (2), National Stock Number, identifies the stock number of the item to be used for requisition purposes.

C.3.3. Column (3), Description an Usable on Code, identifies the federal item name (in all capital letters) follow by a minimum description when needed. The last line below the description is the Commercial and Government Entity Code (CAGEC) (in parentheses) and the part number.

C.3.4. Column (4), U/I (unit of issue), indicates how the item is issued for the National Stock Number shown in column two.

C.3.5. Column (5), Qty Rqd, indicates the quantity required.

SECTION II COMPONENTS OF END ITEM

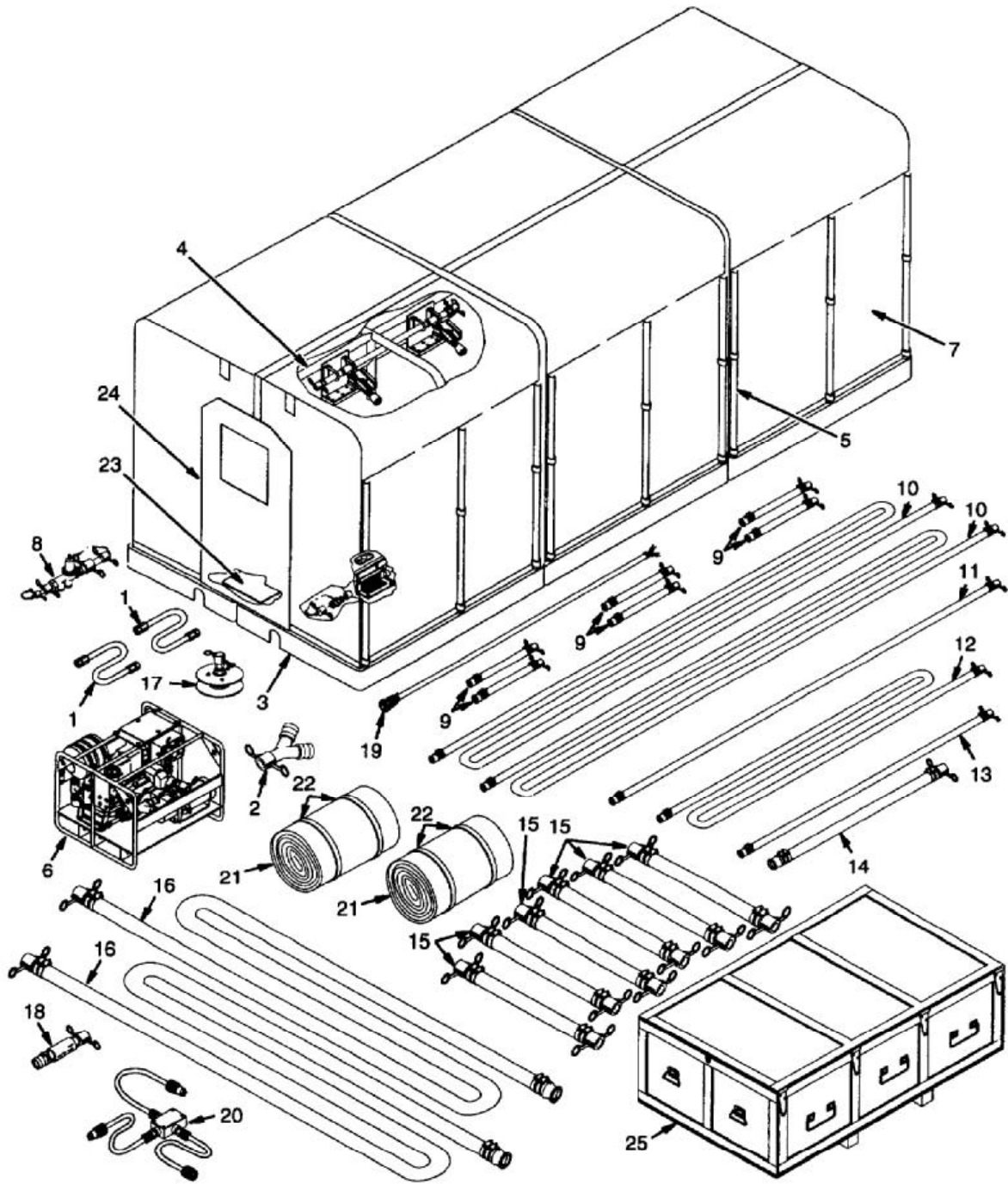

Figure C-1. Component of End Item

(1) Illus Number	(2) National Stock Number	(3) Description CAGEC and Part Number	(4) Usable On Code	(5) Qty Rqd.
1		FUEL HOSE ASSEMBLY (96906) MS 28741-81440	EA	2
2		Y FITTING COUPLER (98752) 8611306	EA	1
3		SHOWER BASE (98752) 8611307	EA	6
4		TOP FRAME ASSEMBLY (98572) 8611312	EA	6
5		SUPPPORT POLES (98752) 8611319	EA	36
6		PUMP ASSEMBLY	EA	1
7		SHOWER COVER (98752) 8611336-400	EA	6
8		REGULATOR VALVE ASSEMBLY (98752) 9317903	EA	1
9		1 INCH X 28-5/8 INCH LONG HOSE ASSEMBLY (98752) 8611345	EA	6
10		1 INCH X 424 INCH LONG HOSE ASSEMBLY (98752) 8611346	EA	2
11		1 INCH X 147 INCH LONG HOSE ASSEMBLY (98752) 8611347	EA	1
12		1 INCH LONG HOSE ASSEMBLY (98752) 8611349-12	EA	1
13		1 INCH X 90 INCH LONG HOSE ASSEMBLY (98752) 8611349-13	EA	1
14		1-1/2 INCH X 60 INCH LONG HOSE ASSEMBLY (98752) 8611350	EA	1
15		2 INCH X 61-7/8 INCH LONG HOSE ASSEMBLY (98752) 8611352	EA	6
16		2 INCH X 424 INCH LONG HOSE ASSEMBLY (98752) 8611353	EA	2
17		WATER SUCTION STRAINER ASSEMBLY (98752) 8611354	EA	1
18		SPRING CHECH VALVE ASSEMBLY (98752) 8611355	EA	1
19		POWER CABLE ASSEMBLY 8611356-20	EA	1
20		POWER CABLE ASSEMBLY 8611356-19	EA	1
21		FLOOR MAT (36 INCH X 20 FEET) (98752) 8611305 ITEM 271	EA	2
22		CLINCHING STRAP (FOR FLOOR MAT) (39428) 3955T67	EA	4
23		FLOOR PANEL (98752) 8611340	EA	3
24		DOOR PANEL (98752) 8611341	EA	2
25		STORAGE CONTAINER (94833) SK17025-1	EA	6

SECTION III BASIC ISSUE ITEMS LIST

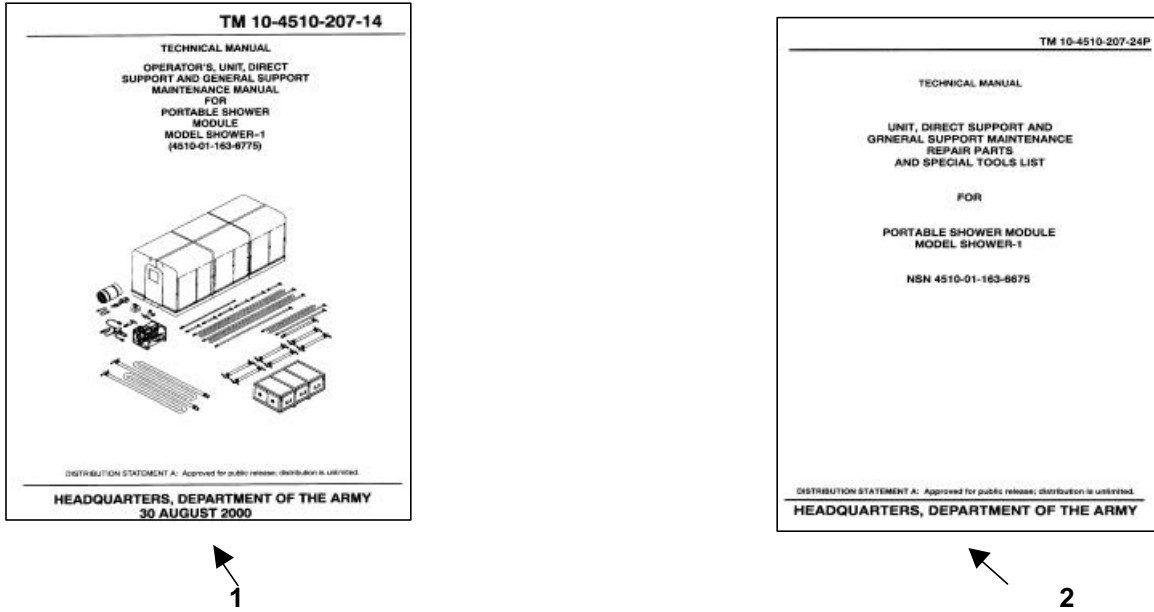

Figure C-2. Basic Issue Items

(1) Illus Number	(2) National Stock Number	(3) Description CAGEC and Part Number	Usable On Code	(4) U/M	(5) Qty Rqd.
1	4520-01-162-0385	ARMY TECHNICAL MANUAL Operator's, Unit, Direct Support and General Support Maintenance for Portable Shower Module, Model SHOWER-1 TM 10-1410-207-14		EA	1
2		ARMY TECHNICAL MANUAL Unit, Direct Support and General Support Maintenance Repair Parts and Special Tools for Portable Shower Module, Model SHOWER-1 TM 10-4510-207-24P		EA	1
		HEATER, WATER, LIQUID FUEL (81349) MIL-H 44086		EA	1
		GENERATOR, ELECTRIC 1.5 Kw (minimum), 3 phase, 60 hertz, 230 v		EA	1

**APPENDIX D
ADDITIONAL AUTHORIZED LIST (AAL)**

There are no additional authorized items required for this portable shower module.

THIS PAGE INTENTIONALLY LEFT BLANK

APPENDIX E EXPENDABLE AND DURABLE ITEMS LIST

SECTION I INTRODUCTION

E.1. SCOPE.

This appendix lists expendable and durable items you will need to maintain the portable shower module. This listing is for informational purposes only and is not authority to requisition the listed items. These items are authorized by CTA 50-970, expendable items (except Medical, Class V, Repair Parts, and Heraldic Items).

E.2. EXPLANATION OF COLUMNS.

E.2.1. Column (1) - Item Number. This number is assigned to the entry in the listing for referencing when required.

E.2.2. Column (2) - Level. This column identifies the lowest level of maintenance that requires the listed item.

C- Operator/Crew

O - Unit Maintenance

F - Direct Support Maintenance

H - General Support maintenance

E.2.3. Column (3) - National Stock Number. This is the national stock number assigned to the item; use it to request or requisition the item.

E.2.4. Column (4) - Description. Indicates federal item name and, if required a description to identify the item. The last line for each item indicates the Commercial and Government Entity Code (CAGEC) in parentheses followed by the part number.

E.2.5. Column (5) - Unit of Measure (U/M) Unit of issue (U/I). This message is expressed by a two character alphabetical abbreviation (e.g., EA, IN, PR). If the unit of measure differs from the unit of issue as shown in the Army Master Data File (AMDF) requisition the lowest unit of issue that will satisfy your requirements.

SECTION II EXPENDABLE AND DURABLE ITEMS LIST

(1) Item Number	(2) Level	(3) National Stock Number	(4) Description	(5) (U/M/ U/I)
1	O	7510-00-266-5006	Sealing Compound, (81349) MIL-S-7916	pt
2	O		Adhesive, (98752) 93107922	qt
3	O	9150-00-985-7361	Grease, Multipurpose, (81349) MIL-G-23549	lb
4	H		Luster Enamel, (81349) 34088/TT-E-527	gl
5	O	9905-00-537-8945	Tag, Marker, (81349) MIL-T-12755	bd

THIS PAGE INTENTIONALLY LEFT BLANK

**APPENDIX F
ILLUSTRATED LIST OF MANUFACTURED ITEMS**

SECTION I INTRODUCTION

F.1. SCOPE.

This appendix indicated complete instructions for making items authorized to be manufactured or fabricated at unit and direct support maintenance.

F.1.1. A part number index in alphanumeric order is provided for across-referencing the part number of the item to be manufactured to the figure, which covers fabrication criteria.

F.1.2. All bulk materials needed for manufacture of an item are listed by part number or specification number in a tabular list on the illustration.

F.1.3. All dimensions are given in inches with centimeters shown in parentheses.

Manufactured Items Part Number Index

<u>Part Number</u>	<u>Figure Number</u>
SK17026 ITEM 1.....	F-7
SK17026 ITEM 2.....	F-7
SK17026 ITEM 3.....	F-7
SK17026 ITEM 4.....	F-6
SK17026 ITEM 5.....	F-6
SK17026 ITEM 6.....	F-6
SK17026 ITEM 7.....	F-6
SK17026 ITEM 8.....	F-6
SK17026 ITEM 9.....	F-6
SK17027 ITEM 1.....	F-7
SK17027 ITEM 2.....	F-6
SK17027 ITEM 3.....	F-6
6811309-63.....	F-2
6811309-64.....	F-2
8611320 ITEM 215.....	F-5
8611320 ITEM 216.....	F-5
8611320 ITEM 217.....	F-5
8611320 ITEM 218.....	F-5
8611344 ITEM105.....	F-4
8611344 ITEM 106.....	F-4
8611344 ITEM 107.....	F-4
8611344 ITEM 108.....	F-4
8611344 ITEM 156.....	F-4

<u>Part Number</u>	<u>Figure Number</u>
8611349 ITEM 109.....	F-4
8611349 ITEM 110.....	F-4
8611350 ITEM 111.....	F-4
8611351 ITEM 112.....	F-4
8611351 ITME 113.....	F-4
8611356-200 /10 FT	F-1
8611356-200/4 FT	F-1
8611356-200/40 FT	F-1
931007924/CHAIN.....	F-3

SECTION II MANUFACTURED ITEMS ILLUSTRATIONS

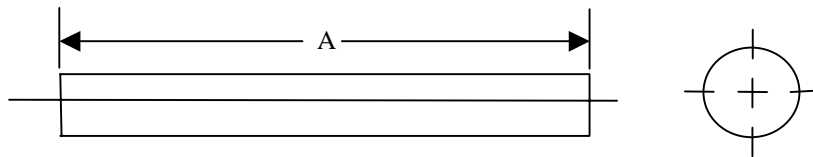

ITEM	PART NO.	DIM "A"	FABRICATE FROM
1	8611356-200/10 FT	120.0 (304.8)	(81349) CO-05HGF (5/12) 0740 ELECTRIC CABLE
2	8611356-200/4 FT	48.0 (121.9)	(81349) CO-05HGF (5/12) 0740 ELECTRIC CABLE
3	8611356-200/40 FT	480.0 (1219.2)	(81349) CO-05HGF (5/12) 0740 ELECTRIC CABLE

Figure F-1. Electric Cable

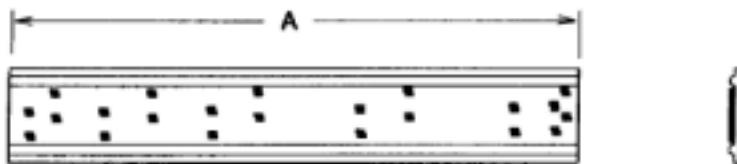

ITEM	PART NO.	DIM "A"	FABRICATE FROM
1	8611309-63	65.50 (166.37)	(81349) MIL-F-21840, TYPE 1, CLASS 1, 1 IN., 80 HOOK VELCRO EXTRUSION
2	8611309-64	26.50 (67.31)	(81349) MIL-F-21840, TYPE 1, CLASS 1, 1 IN., 80 HOOK VELCRO EXTRUSION

Figure F-2. Velcro Extrusion

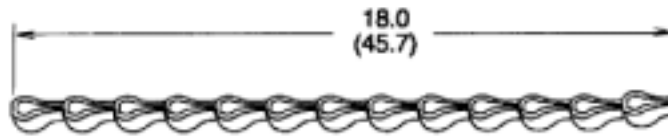

NOTE

1. FABRICATE FROM (81348) RR-C-271/II, 3, SST, 35 WELDLESS SAFETY CHAIN

Figure F-3. Chain, Safety, Part Number 93107924/CHAIN

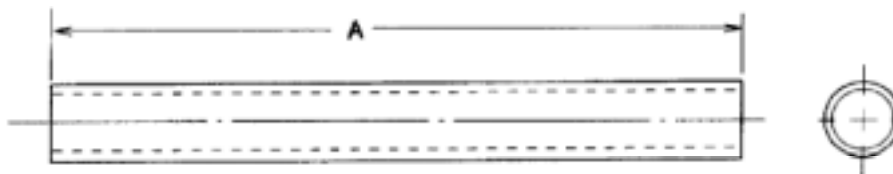

ITEM	PART NO.	DIM "A"	FABRICATE FROM
1	8611344-105	25.50 (64.77)	(24161) 1 LB BLACK 1.00 INCH (2.54 CM) I. D. HOSE
2	8611344-106	420.00 (1066.80)	(24161) 1 LB BLACK 1.00 INCH (2.54 CM) I. D. HOSE
3	8611344-107	144.00 (365.76)	(24161) 1 LB BLACK 1.00 INCH (2.54 CM) I. D. HOSE
4	8611344-108	12.00 (30.48)	(24161) 1 LB BLACK 1.00 INCH (2.54 CM) I. D. HOSE
5	8611344-156	13.75 (34.93)	(24161) 1 LB BLACK 1.00 INCH (2.54 CM) I. D. HOSE
6	8611349 ITEM 109	300.00 (762.00)	(62543) 55-1776-43, 1.00 INCH (2.54 CM) I. D. HOSE
7	8611349 ITEM 110	90.00 (228.60)	(62543) 55-1776-43, 1.00 INCH (2.54 CM) I. D. HOSE
8	8611350 ITEM 111	61.00 (154.94)	(62543) 55-1776-49, 1.50 INCH (3.81 CM) I. D. HOSE
9	8611351 ITEM 112	58.00 (147.32)	(25472) 89-83-4020-00, 2.00 INCH (5.08 CM) I. D. HOSE
10	8611351 ITEM 113	420.00 (1066.80)	(25472) 89-83-4020-00, 2.00 INCH (5.08 CM) I. D. HOSE

Figure F-4. Hoses, Various

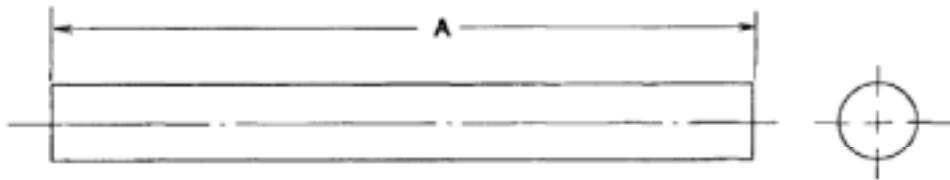

ITEM	PART NO.	DIM "A"	FABRICATE FROM
1	8611320 ITEM 215	48.00 (121.92)	(81349) M16878/4BLE5, WIRE, ELECTRIC, INSULATED 12 AWG, GREEN
2	8611320 ITEM 216	48.00 (121.92)	(81349) M16878/4BLE3, WIRE, ELECTRIC, INSULATED 12 AWG, ORANGE
3	8611320 ITEM 217	48.00 (121.92)	(81349) M16878/4BLE2, WIRE, ELECTRIC, INSULATED 12 AWG, RED
4	8611320 ITEM 218	48.00 (121.92)	(81349) M16878/4BLE0, WIRE, ELECTRIC, INSULATED 12 AWG, BLACK

Figure F-5. Electric Wire

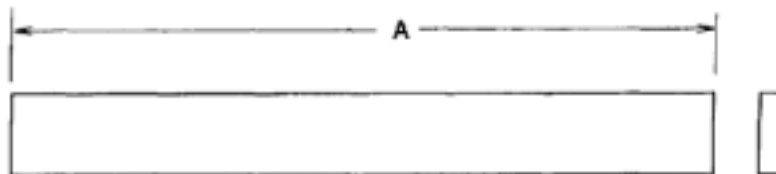

ITEM	PART NO.	DIM "A"	FABRICATE FROM
1	SK17026 ITEM 4	18.75 (47.63)	1 X 3 LUMBER (PINE)
2	SK17026 ITEM 5	73.00 (185.42)	1 X 3 LUMBER (PINE)
3	SK17026 ITEM 6	46.50 (118.11)	1 X 3 LUMBER (PINE)
4	SK17026 ITEM 7	75.50 (191.77)	1 X 3 LUMBER (PINE)
5	SK17026 ITEM 8	41.25 (104.78)	1 X 3 LUMBER (PINE)
6	SK17026 ITEM 9	46.50 (118.11)	4 X 4 LUMBER (PRESSURE TREATED)
7	SK17027 ITEM 2	41.25 (104.78)	1 X 3 LUMBER (PINE)
8	SK17027 ITEM 3	75.50 (191.77)	1 X 3 LUMBER (PINE)

Figure F-6. Lumber

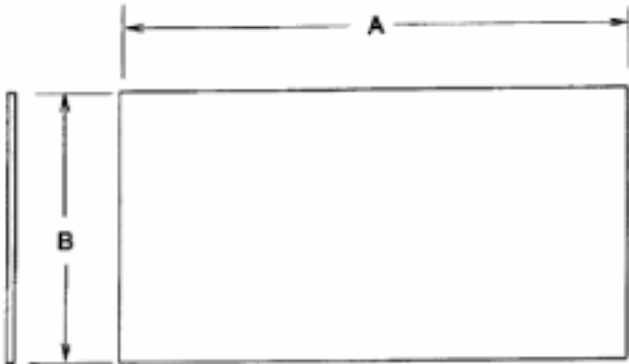

ITEM	PART NO.	DIM *A*	DIM *B*	FABRICATE FROM
1	SK17026 ITEM 1	46.50 (118.11)	75.50 (191.77)	0.50 (1.27) GRADE AC PLYWOOD
2	SK17026 ITEM 2	24.00 (60.96)	46.50 (118.11)	0.50 (1.27) GRADE AC PLYWOOD
3	SK17026 ITEM 3	24.00 (60.96)	73.00 (185.42)	0.50 (1.27) GRADE AC PLYWOOD
4	SK17027 ITEM 1	46.50 (118.11)	75.50 (191.77)	0.50 (1.27) GRADE AC PLYWOOD

Figure F-7. Plywood

THIS PAGE INTENTIONALLY LEFT BLANK

APPENDIX G
MANDATORY REPLACEMENT PARTS

Item Number	Nomenclature	Part number
1	Self locking Nut	(96906) MS21044C4
2	Elastic Stop Nut	(98752) 8611345 ITEM 186
3	Lock Washer	(98752) 8611320 ITEM 182
4	Lock Washer	(98752) 8611325 ITEM 299
5	Lock Washer	(98752) 93107912 ITEM 230
6	Self Locking nut	(96906) MS51922-18
7	Lock Washer	(96906) MS35338-139
8	Self Locking Nut	(96906) MS51922-6
9	Lock Washer	(98752) 8611320 ITEM 184
10	Lock Washer	(10190) 3/8
11	Lock Washer	(19548) 3/8" LOCK WASHER
12	Lock Washer	(19548) 5/16" LOCK WASHER
13	Lock Washer	(19548) 1/4" LOCK WASHER
14	Sealing Washer	(19548) 160-A-1200
15	ID Strap	(56501) TY 553M

THIS PAGE INTENTIONALLY LEFT BLANK

ALPHABETICAL LIST

A	O
Administrative Storage And Shipment..... 4.19	Operating Procedures2.7
Assembly And Preparation For Use.....2.6	
C	P
Characteristics, Capabilities, And Features.....1.9	Portable Shower Base Repair Or Replacement....4.6
Common Tools And Equipment.....4.1	Power Cable Assemblies Repair.....5.1
Corrosion Prevention And Control (CPC)1.8	Power Cable Assemblies Testing And Replacement4.5
D	Preparation For Storage Or Shipment.....1.4
Destruction Of Army Materiel To Prevent	Pump Assembly Frame Repair6.1
Enemy Use.....1.3	Pump Assembly Frame Replacement5.4
Diaphragm (Drain) Pump 1.15	
Diaphragm (Drain) Pump Assembly Repair.....5.3	Q
Diaphragm (Drain) Pump Assembly Replacement4.16	Quality Assurance.....1.5
Diaphragm (Drain) Pump Switch.....2.2	R
Diaphragm Tank & Fittings Repair Or Replacement4.17	Regulator Assembly (Temperature) Repair Or Replacement4.15
Door Panel Replacement.....3.2	Regulator Valve Assembly Repair Or Replacement4.10
E	Repair Parts4.3
Equipment Data..... 1.11	Reporting Equipment Improvement Recommendations (EIR).....1.6
F	S
Floor Mat Replacement3.4	Scope1.1
Floor Panel Replacement3.6	Shower Cover Replacement.....3.3
I	Shower Facility Interconnection Hose Assemblies Repair Or Replacement.....4.11
Introduction2.5	Shower Head.....1.14
Introduction4.4	Special Tools, TMDE, And Support Equipment.....4.2
L	Spring Check Valve Assembly Repair Or Replacement4.9
Location And Description Of Major Components..... 1.10	Storage Container Repair.....4.18
M	Storage Container Replacement.....5.5
Maintenance Forms, Records And Reports.....1.2	Strainer Assembly Repair Or Replacement4.8
	Supply Pump.....1.12
	Supply Pump Assembly Repair.....5.2
	Supply Pump Assembly Replacement.....4.14
	Supply Pump Cold Line Hose Assemblies Repair Or Replacement4.12
	Supply Pump Switch.....2.1
	Switch Box Assembly Testing, Repair, Or Replacement4.13

T

Temperature Gauge2.4
Temperature Regulator..... 1.13
Temperature Regulator.....2.3
Top Frame Assembly Repair Or Replacement.....4.7

V

Vertical Support Replacement.....3.5

W

Warranty Information.....1.7

Y

Y-Fitting Coupler Replacement3.1

TM 10-4510-207-14

By Order of the Secretary of the Army:

ERIC K. SHINSEKI
General, United States Army
Chief of Staff

Official:

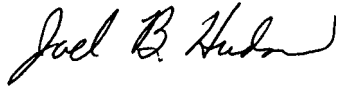

JOEL B. HUDSON
Administrative Assistant to the
Secretary of the Army
0017206

DISTRIBUTION:

To be distributed in accordance with initial distribution (IDN 256493), requirements for TM 10-4510-207-14.

THIS PAGE INTENTIONALLY LEFT BLANK

These are the instructions for sending an electronic 2028

The following format must be used if submitting an electronic 2028. The subject line must be exactly the same and all fields must be included; however only the following fields are mandatory: 1, 3, 4, 5, 6, 7, 8, 9, 10, 13, 15, 16, 17, and 27.

From: "Whomever" <whomever@avma27.army.mil>

To: amssb-rim-e@natick.army.mil

Subject: DA Form 2028

1. **From:** Joe Smith
2. **Unit:** home
3. **Address:** 4300 Park
4. **City:** Hometown
5. **St:** MO
6. **Zip:** 77777
7. **Date Sent:** 19-OCT-93
8. **Pub no:** 55-2840-229-23
9. **Pub Title:** TM
10. **Publication Date:** 04-JUL-85
11. **Change Number:** 7
12. **Submitter Rank:** MSG
13. **Submitter FName:** Joe
14. **Submitter MName:** T
15. **Submitter LName:** Smith
16. **Submitter Phone:** 123-123-1234
17. **Problem:** 1
18. **Page:** 2
19. **Paragraph:** 3
20. **Line:** 4
21. **NSN:** 5
22. **Reference:** 6
23. **Figure:** 7
24. **Table:** 8
25. **Item:** 9
26. **Total:** 123
27. **Text:**

This is the text for the problem below line 27.

THIS PAGE INTENTIONALLY LEFT BLANK



THEN . . . JOT DOWN THE DOPE ABOUT IT ON THIS FORM, CAREFULLY TEAR IT OUT, FOLD IT AND DROP IT IN THE MAIL!

SOMETHING WRONG WITH THIS PUBLICATION?

FROM: (PRINT YOUR UNIT'S COMPLETE ADDRESS)

*PFC John DOE
CO A 3rd Engineer Bn
Ft. Leonardwood, MO 63108*

DATE SENT

22 August 1992

PUBLICATION NUMBER

TM 1-1520-250-10

PUBLICATION DATE

15 June 1992

PUBLICATION TITLE

Operator's manual MH60K Helicopter

BE EXACT PIN-POINT WHERE IT IS

IN THIS SPACE, TELL WHAT IS WRONG AND WHAT SHOULD BE DONE ABOUT IT:

PAGE NO	PARA-GRAPH	FIGURE NO	TABLE NO
6	2-1 a		
B1		4-3	

In line 6 of paragraph 2-1a the manual states the engine has 6 cylinders. The engine on my set only has 4 cylinders. Change the manual to show 4 cylinders.

Callout 16 on figure 4-3 is pointed at a bolt. In key to figure 4-3, item 16 is calle a shim. Please correct one or the other

PRINTED NAME, GRADE OR TITLE, AND TELEPHONE NUMBER

JOHN DOE, PFC (268) 317-7111

SIGN HERE

JOHN DOE John Doe

FILL IN YOUR
UNITS ADDRESS



FOLD BACK

DEPARTMENT OF THE ARMY

OFFICIAL BUSINESS

COMMANDER
U.S. ARMY SOLDIER SYSTEMS COMMAND
ATTN: AMSSB-RIM-E
KANSAS STREET
NATICK, MA 91760-5000

TEAR ALONG PERFORATED LINE



SOMETHING WRONG WITH THIS PUBLICATION?

THEN . . . JOT DOWN THE DOPE ABOUT IT ON THIS FORM, CAREFULLY TEAR IT OUT, FOLD IT AND DROP IT IN THE MAIL!

FROM: (PRINT YOUR UNIT'S COMPLETE ADDRESS)

DATE SENT

PUBLICATION NUMBER
TM 10-4510-207-14

PUBLICATION DATE
30 August 2000

PUBLICATION TITLE
Portable Shower Module, Model Shower-1

BE EXACT PIN-POINT WHERE IT IS IN THIS SPACE, TELL WHAT IS WRONG AND WHAT SHOULD BE DONE ABOUT IT:

PAGE NO	PARA-GRAPH	FIGURE NO	TABLE NO

PRINTED NAME, GRADE OR TITLE, AND TELEPHONE NUMBER

SIGN HERE

FILL IN YOUR
UNITS ADDRESS



FOLD BACK

DEPARTMENT OF THE ARMY

OFFICIAL BUSINESS

COMMANDER
U.S. ARMY SOLDIER SYSTEMS COMMAND
ATTN: AMSSB-RIM-E
KANSAS STREET
NATICK, MA 91760-5000

TEAR ALONG PERFORATED LINE



THEN . . . JOT DOWN THE DOPE ABOUT IT ON THIS FORM, CAREFULLY TEAR IT OUT, FOLD IT AND DROP IT IN THE MAIL!

SOMETHING WRONG WITH THIS PUBLICATION?

FROM: (PRINT YOUR UNIT'S COMPLETE ADDRESS)

DATE SENT

PUBLICATION NUMBER
TM 10-4510-207-14

PUBLICATION DATE
30 August 2000

PUBLICATION TITLE
Portable Shower Module, Model Shower-1

BE EXACT PIN-POINT WHERE IT IS IN THIS SPACE, TELL WHAT IS WRONG AND WHAT SHOULD BE DONE ABOUT IT:

PAGE NO	PARA-GRAPH	FIGURE NO	TABLE NO

PRINTED NAME, GRADE OR TITLE, AND TELEPHONE NUMBER

SIGN HERE

FILL IN YOUR
UNITS ADDRESS



FOLD BACK

DEPARTMENT OF THE ARMY

OFFICIAL BUSINESS

COMMANDER
U.S. ARMY SOLDIER SYSTEMS COMMAND
ATTN: AMSSB-RIM-E
KANSAS STREET
NATICK, MA 91760-5000

TEAR ALONG PERFORATED LINE



THEN . . . JOT DOWN THE DOPE ABOUT IT ON THIS FORM, CAREFULLY TEAR IT OUT, FOLD IT AND DROP IT IN THE MAIL!

SOMETHING WRONG WITH THIS PUBLICATION?

FROM: (PRINT YOUR UNIT'S COMPLETE ADDRESS)

DATE SENT

PUBLICATION NUMBER
TM 10-4510-207-14

PUBLICATION DATE
30 August 2000

PUBLICATION TITLE
Portable Shower Module, Model Shower-1

BE EXACT PIN-POINT WHERE IT IS IN THIS SPACE, TELL WHAT IS WRONG AND WHAT SHOULD BE DONE ABOUT IT:

PAGE NO	PARA-GRAPH	FIGURE NO	TABLE NO

PRINTED NAME, GRADE OR TITLE, AND TELEPHONE NUMBER

SIGN HERE

FILL IN YOUR
UNITS ADDRESS



FOLD BACK

DEPARTMENT OF THE ARMY

OFFICIAL BUSINESS

COMMANDER
U.S. ARMY SOLDIER SYSTEMS COMMAND
ATTN: AMSSB-RIM-E
KANSAS STREET
NATICK, MA 91760-5000

TEAR ALONG PERFORATED LINE

The Metric System and Equivalents

Linear Measure

1 centimeter = 10 millimeters = .39 inch
 1 decimeter = 10 centimeters = 3.94 inches
 1 meter = 10 decimeters = 39.37 inches
 1 dekameter = 10 meters = 32.8 feet
 1 hectometer = 10 dekameters = 328.08 feet
 1 kilometer = 10 hectometers = 3,280.8 feet

Weights

1 centigram = 10 milligrams = .15 grain
 1 decigram = 10 centigrams = 1.54 grains
 1 gram = 10 decigrams = .035 ounce
 1 dekagram = 10 grams = .35 ounce
 1 hectogram = 10 dekagrams = 3.52 ounces
 1 kilogram = 10 hectograms = 2.2 pounds
 1 quintal = 100 kilograms = 220.46 pounds
 1 metric ton = 10 quintals = 1.1 short tons

Liquid Measure

1 centiliter = 10 milliliters = .34 fl. ounce
 1 deciliter = 10 centiliters = 3.38 fl. ounces
 1 liter = 10 deciliters = 33.81 fl. ounces
 1 dekaliter = 10 liters = 2.64 gallons
 1 hectoliter = 10 dekaliters = 26.42 gallons
 1 kiloliter = 10 hectoliters = 264.18 gallons

Square Measure

1 sq. centimeter = 100 sq. millimeters = .155 sq. inch
 1 sq. decimeter = 100 sq. centimeters = 15.5 sq. inches
 1 sq. meter (centare) = 100 sq. decimeters = 10.76 sq. feet
 1 sq. dekameter (are) = 100 sq. meters = 1,076.4 sq. feet
 1 sq. hectometer (hectare) = 100 sq. dekameters = 2.47 acres
 1 sq. kilometer = 100 sq. hectometers = .386 sq. mile

Cubic Measure

1 cu. centimeter = 1000 cu. millimeters = .06 cu. inch
 1 cu. decimeter = 1000 cu. centimeters = 61.02 cu. inches
 1 cu. meter = 1000 cu. decimeters = 35.31 feet

Approximate Conversion Factors

<i>To change</i>	<i>To</i>	<i>Multiply by</i>	<i>To change</i>	<i>To</i>	<i>Multiply by</i>
inches	centimeters	2.540	ounce-inches	newton-meters	.007062
feet	meters	.305	centimeters	inches	.394
yards	meters	.914	meters	feet	3.280
miles	kilometers	1.609	meters	yards	1.094
square inches	square centimeters	6.451	kilometers	miles	.621
square feet	square meters	.093	square centimeters	square inches	.155
square yards	square meters	.836	square meters	square feet	10.764
square miles	square kilometers	2.590	square meters	square yards	1.196
acres	square hectometers	.405	square kilometers	square miles	.386
cubic feet	cubic meters	.028	square hectometers	acres	2.471
cubic yards	cubic meters	.765	cubic meters	cubic feet	35.315
fluid ounces	milliliters	29.573	cubic meters	cubic yards	1.308
pints	liters	.473	milliliters	fluid ounces	.034
quarts	liters	.946	liters	pints	2.113
gallons	liters	3.785	liters	quarts	1.057
ounces	grams	28.349	liters	gallons	.264
pounds	kilograms	.454	grams	ounces	.035
short tons	metric tons	.907	kilograms	pounds	2.205
pound-feet	newton-meters	1.356	metric tons	short tons	1.102
pound-inches	newton-meters	.11296			

Temperature (Exact)

_F	Fahrenheit temperature	5/9 (after subtracting 32)	Celsius temperature	_C
----	---------------------------	-------------------------------	------------------------	----

